

# STSQ-HD/26



**GERVASI**

Excellence in technology

# STSQ Heavy Duty/ 26

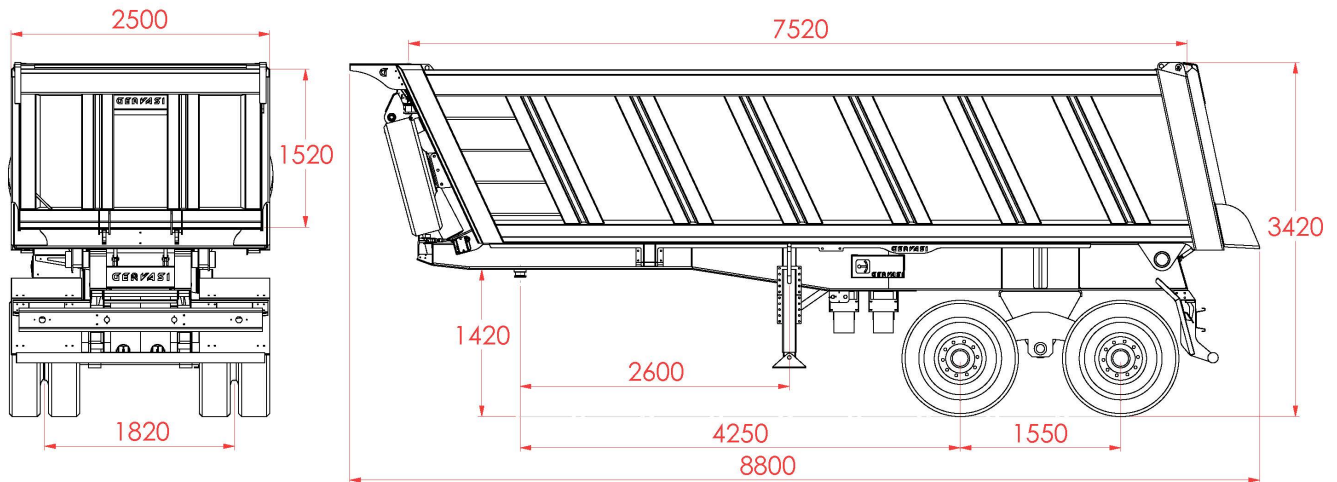

## EMPLOY

- Suitable for the transport of rocks inert materials.

## EQUIPMENT

### Sub Frame

- Sub frame in high resistance steel, suitable for heavy works
- No. 2 axles x 14 Ton at cantilever suspensions
- 8 wheels + 1 spare wheel 13.00 R 22,5 by leading brands with steel discs
- Braking system with drum brakes
- Manual mechanical movement stabilizers
- Parking wedges and their holders
- King pin 3,5"
- Water Painting cycle:
  - Sandblasting SA 2,5 by means of computerized system
  - Primer and Water Finishing enamel GREY RAL7021

### Tipper Body

- Walls with reinforcing upwards fashioned and welded continuously
- Fixed side walls
- Rear Gate with automatic mechanic release during tipping
- Tipping system by means of telescopic cylinder mounted in frontal position
- Front gate with cab protection lid and spare-wheel winch
- Tool box
- Rear semi-mudguards
- Rear fixed protection bar
- Reflective pannels and strips
- Water Painting cycle:
  - Sandblasting SA 2,5 by means of computerized system
  - Acrylic primer and finishing color for Your choice

**BODY VOLUME**

**TOTAL DEAD WEIGHT OF THE SEMITRAILER**

**TECHNICALLY PERMISSIBLE TOTAL WEIGH**

**KING PIN LOAD**

**FLOOR**

**SIDE WALLS**

**BODY LIFTING ANGLE**

26 m<sup>3</sup>

10000 kg

59000 kg

21000 kg

ST52 Thickness 6 mm

ST52 Thickness 4 mm

47°

DEALER



The dimensions and weights are indicative. They can be changed without warning for manufacturing needs. Gervasi S.p.a.

**GERVASI**

S.S. 23 del Sestriere km 29 - 10060 Scalenghe (TURIN) Italy  
Tel: + 39 011 9866039 Fax: + 39 011 9866750 - www.gervasi-spa.it