

HD9

chassis 8x4

84.38 / 84.42 / 84.44 / 84.48 / 84.54

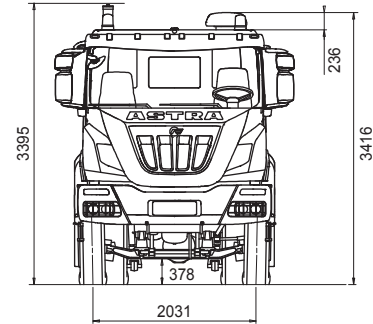
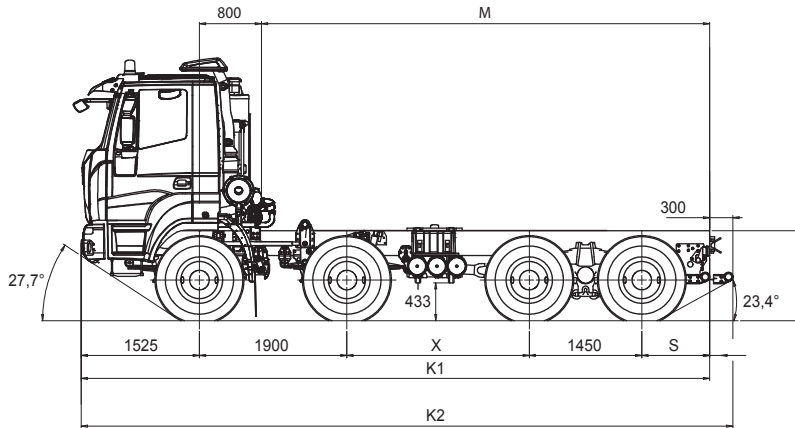

ON REQUEST
RHD VERSION
LONG CAB VERSION



DIMENSIONS (mm) short cab (Tyres 13R22.5 156/150G)

X	K1	K2	M max (*)	S	S ON REQUEST	H		TURNING DIAMETER	
						unloaded	loaded	sidewalks	wall to wall
2350	8425	8725	6100	1200	875/1500	1194	1129	17500	19100
2600	8675	8975	6350	1200	875/1500			18200	19900
2850	8925	9225	6600	1200	875/1500			19000	20700
3100	9175	9475	6850	1200	875/1500			19800	21500
3350	9425	9725	7100	1200	1500			20600	22200
3600	9975	10275	7650	1500				21300	23000
4100	10475	10775	8150	1500				22900	24600
5060	12035	12335	9710	2100				25800	27500

(*) M max.: indicative value to be confirmed by bodybuilder.



WEIGHT (kg)

Distribution net weight (*)					Max technical weight				
X	1 st axle	2 nd axle	3 rd + 4 th axle	NET WEIGHT	1 st + 2 nd axle		3 rd + 4 th axle	Gross Vehicle Weight	Gross Combination Weight
2350	3550	3150	4120	10820	16000	18000 (1)	32000	50000 (2)	104000
2600	3543	3143	4159	10845					
2850	3536	3136	4194	10865					
3100	3548	3148	4268	10965					
3350	3546	3146	4298	10990					
3600	3534	3134	4363	11030					
4100	3529	3129	4417	11075					
5060	3502	3102	4536	11140					

(*) Weight including oil, fuel, spare wheel, driver Kg.75

(1) With tyres 1st axle 385/65R22,5160J or 365/85R20164G and reinforced suspension (OPT).

(2) Max speed 70 km/h with Continental/Michelin tyres. Higher speeds are allowed with load reductions, subject to the Astra technical office approval.

Technical data and general specifications - validity to be checked according to each individual country



ENGINES

CURSOR 13 turbo intercooler **euro 3** diesel injection/cycle with electronic unit injection pumps. Single block head, four valves per cylinder, light alloy pistons. Total displacement: 12.882 cm³. Bore for stroke: 135 x 150 mm. 6 in-line cylinders. Water cooling. Viscostatic cooling fan. Dry air filter with safety cartridge. Vertical muffler.

	84.38	84.42	84.44	84.48	84.54*
Model	IVECO F3B	IVECO F3B	IVECO F3B	IVECO F3B	IVECO F3B
Max power (EEC)	280 kW (380 cv)	309 kW (420 cv)	324 kW (440 cv)	353 kW (480 cv)	397 kW (540 cv)
Corresponding rpm	1.900				
Max torque (EEC)	1.800 Nm (183 kgm)	1.900 Nm (194 kgm)	2.100 Nm (214 kgm)	2.200 Nm (224 kgm)	2.350 Nm (240 kgm)
Corresponding rpm	1.000-1.440				1.000-1.690
Turbine	WG Waste Gate			VGT variable geometry	

*Requires additional engine radiator, for extremely hot climate (>42°C).



GEARBOX

Manual ZF Ecosplit 4 technology gearbox with servoshift, 16 synchronised forward speeds + 2 reverse:

ZF16S2220TO: HD9 84.38/HD9 84.42 / HD9 84.44

ZF16S2520TO: HD9 84.48/HD9 84.54

On request:

ZF16S2320TD: HD9 84.38/HD9 84.42/ HD9 84.44/ HD9 84.48

ZF ASTRONIC 16AS2601OD: HD9 84.44/ HD9 84.48/ HD9 84.54

		Speed [kph] at maximum power(*)																		
		Gears																		
		1	2	3	4	5	6	7	8	9	10	11	12	13	14	15	16	RM1	RM2	
ZF 16S2220TO ZF 16S2520TO	Gear ratios	16.41	13.80	11.28	9.49	7.76	6.53	5.43	4.57	3.59	3.02	2.47	2.08	1.70	1.43	1.19	1.00	15.36	12.92	
	Rear axle ratio	3.793	7.5	8.9	10.9	13.0	15.8	18.9	22.5	27.0	34.1	40.7	49.5	59.2	72.0*	85.9*	103*	122.7*	8.0	9.5
		4.229	6.7	8.0	9.7	11.7	14.2	16.9	20.2	24.2	30.6	36.5	44.4	53.1	64.6	77.0*	92.4*	110.0*	7.2	8.6
		5.009	5.7	6.8	8.2	9.8	11.9	14.3	17.1	20.4	25.8	30.8	37.5	44.8	54.6	65.0	78.0*	92.9*	6.0	7.2
		5.558	5.1	6.1	7.4	8.9	10.8	12.9	15.4	18.4	23.3	27.8	33.8	40.4	49.2	58.6	70.3*	83.7*	5.4	6.5
		6.095	4.6	5.6	6.8	8.1	9.8	11.7	14.0	16.8	21.2	25.3	30.8	36.8	44.8	53.4	64.1	76.3*	5.0	5.9
6.588	4.3	5.1	6.3	7.5	9.1	10.9	13.0	15.5	19.6	23.4	28.5	34.1	41.5	49.4	59.3	70.6*	4.6	5.5		
ZF16S2320TD	Gear ratios	16.41	13.80	11.28	9.49	7.76	6.53	5.43	4.57	3.59	3.02	2.47	2.08	1.70	1.43	1.19	1.00	15.36	12.92	
	Rear axle ratio	3,793	6,3	7,5	9,1	10,9	13,3	15,8	19	22,5	28,7	34,1	41,7	49,5	60,6	72*	86,6*	103*	6,7	8
		4,229	5,6	6,7	8,2	9,7	11,9	14,2	17	20,2	25,7	30,6	37,4	44,4	54,4	64,6	77,7*	92,4*	6	7,2
		5,009	4,8	5,7	6,9	8,2	10,1	11,9	14,4	17,1	21,7	25,8	31,6	37,5	45,9	54,6	65,6	78*	5,1	6
		5,558	4,3	5,1	6,2	7,4	9,1	10,8	12,9	15,4	19,6	23,3	28,5	33,8	41,4	49,2	59,1	70,3*	4,6	5,4
		6,095	3,9	4,6	5,7	6,8	8,3	9,8	11,8	14	17,9	21,2	26	30,8	37,7	44,8	53,9	64,1	4,2	5
6,588	3,6	4,3	5,3	6,3	7,6	9,1	10,9	13	16,5	19,6	24	28,5	34,9	41,5	49,8	59,3	3,9	4,6		

(*) Max speed 90 km/h. Other speeds available, subject to the Astra technical office approval.



P.T.O.

On request:

Gearbox	ZF16S2220TO-ZF16S2520TO	Mx. Torque	Application
P.T.O.	Ratio	Nm	
ZF NH/1b	0,91/1,09:1	1000	For tipping unit pumps, pumps for cranes, ecc.
ZF NH/1c	0,91/1,09:1	1000	For tipping unit pumps, unit pumps for concrete, pumps for cranes, ecc.
ZF NH/4c	1,17/1,40:1	430	For tipping unit pumps, ecc.
ZF N221/10bpl+N353/1c	1,75/2,09:1+0,91/1,09:1	560+600	double PTO for concrete pumps

ZF NMV 221 Power take-off (ratio 1,55:1) max available torque 1300 Nm for concrete pumps (only for 380, 420 and 440 HP).

ZF NMV 221 Power take-off (ratio 0,98:1) max available torque 2000 Nm for concrete pumps (only for 380, 420 and 440 HP).

Power take off at flywheel (ratio 1,29:1) max available torque 900 Nm for concrete mixers.



CLUTCH

Single dry plate, diameter 17". Pull type engagement with diaphragm spring.

Hydro-pneumatic power steering engagement control, with driven disk wear recovery slave cylinder.

On request: Ceramic clutch 17"



AXLES

FRONT

Steering axles, hot moulding in high tensile steel. Wheel stud protection.

REAR

Two tandem drive axles. Double reduction: central with crown wheel and pinion and final in wheel hubs by epicyclic group.

2nd axle with torque distributor to the two rear axles.

Lockable differentials by pneumatic control from driver's seat.

Tandem assembled to the chassis by reaction rods with silentblock.

On request:

Rear-axle ratio 1:3,793

Rear-axle ratio 1:4,229

Rear-axle ratio 1:5,009

Rear-axle ratio 1:5,558

Rear-axle ratio 1:6,095

Rear-axle ratio 1:6,588



SUSPENSIONS

FRONT

1st and 2nd axle, parabolic springs, n° 3 leaves 26x90 mm, shock absorbers and stabilizer bar on 1st axle.

On request:

Stabilizer bar on 2nd axle.

Reinforced parabolic springs, n° 4 leaves 26x90 mm.

Mandatory with 18t load on 1st and 2nd axle.

REAR

Parabolic springs, swivelling on central pin: n° 4 leaves 40x100 mm, torque bars and stiffening brackets.

Stabilizer bar on 4th axle.

On request:

Stabilizer bar on 3rd axle.

Extra-reinforced conventional springs, n° 10 leaves 25x100 mm. Mandatory for heavy duty version.



CHASSIS

Special steel with high elasticity limit, two flat and parallel side members width 820 mm., C section 320x90x10mm, cross members riveted to the frame.

Steel front bumpers with headlamp protection grids, front manoeuvring hook, rear underrun bar, rubber mud-guard 2nd axle, steel fuel tank capacity 300 litres.

On request:

Rapid attachment for compressed air for tyres'inflation.

Rear underrun bar in set back position.

Extra long underrun bar for concrete mixer.

Front bumper climbing step.

Rear manoeuvring hook.

Rear automatic towing hook.

Rubber mudguards on 3rd and 4th axle.

Side windlass for spare wheel (wheelbases 2350 and 2850 excluded)



TYRES

FRONT: 315/80R22,5 156/150 G Single tubeless

REAR: 315/80R22,5 156/150 G Twin tubeless

Spare wheel on the chassis.

Other Possible combinations:

TYRES	ASSEMBLY	
	FRONT	REAR
13R22,5 156/150 G 12 00 R 20 156/150G 315/80 R 22,5 156/150G	S	D
365/85 R 20 164 G	S	
13R22,5 156/150 G 12 00 R 20 156/150G		D
385/65 R 20 164 K	S	
315/80 R 22,5 156/150G		D

S single

D double

Other tyres available, subject to the Astra technical office approval.



STEERING

ZF 8099 quadrilateral power steering on front axle wheels with variable ratio 1:22.2/1:26.2 with auxiliary cylinder.

Circuit with main hydraulic pump on engine and emergency pump on gearbox. Steering rods with self-lubricating joints.

Height and inclination mechanical adjustable steering wheel.



PNEUMATIC SYSTEM

Two-cylinder 630 cc compressor , APU (Air Processing Unit) that includes: regulation valve set at 10.3 bar, drier, 4-way safety valve, pressure reduction valve for parking circuit and services, 3 air tanks, capacity 30 litres + 2 with 20 litres. ABS system and EBL (Electronic Brake Limiter).



BRAKES

Front and rear "duo-duplex" self-adjusting wedge type brakes with automatic play take-up.

Total net braking surface 12.368 cm².

ABS system.

Service brake: Pedal controlled air brake, acting on all wheels.

Solo vehicles, two independent circuits, one for 1st and 2nd axle, one for 3rd and 4th axle.

Towing vehicles, three independent circuits, one for 1st and 2nd axle, one for 3rd and 4th axle and another for the trailer.

Emergency brake: Incorporated in service brake.

Parking brake: Mechanical spring-type with pneumatic control acting on 3rd and 4th axle wheels.

IVECO BRAKE TURBO engine brake:

HD9 380/420 HP braking power 200 kW (272 HP)

HD9 440/480/540 HP braking power 295 kW (408 HP)

On request:

Hydraulic intarder (HD9 84.38 and HD9 84.42 excluded).

1st axle immobiliser system.

OFF/ROAD button for excluding ABS for speed < 15 kph.

HD9 380/420 cv - Front and rear "simplex" self-adjusting brakes system.

No ABS system.

No hydraulic intarder



ELECTRICAL SYSTEM

Voltage: 24 V
 Alternator generator 90 A - 28 V (2520 W).
 Accumulators: 2 in series, 160 Ah.
 Starter motor 24 V 5,5 kW.
 Mechanically controlled electrical circuit breaker.
 Phonic wheels and sensors on 1st and 3rd axle.
 1 electrical joint 7-pole (ISO 7638) for trailer ABS (if applicable).
 1 electrical joint 15-pole (ISO 12089-4091) for trailer lighting (if applicable).
 Electrical provision for bodybuilders.
 Provision for diagnostics.
 Provision for radio/cb (without speakers)
 Glow plug for cold start.

On request:

160 Ah tropicalised accumulators;
 170 Ah accumulators;
 170 Ah tropicalised accumulators;
 Reverse alarm.



CAB

White cab built in galvanized pressed steel with hydraulic tilting up to 60°. Cab suspension with 4 helicoidal springs with coaxial shock absorbers and integrated dampers, anti-roll bar and end-of-stroke pads. Tinted electric door windows. Mechanical rear view mirrors, wide angle mirrors and front view mirror. Internal panels completely washable and fire-proof. Compressed air quick coupling for cab cleaning. 4-speed ventilation and heating system with air recirculation system. Air suspended 3-way adjustable driver seat with seat belts. Mechanical passenger seat with seat belts.

On request:

Air conditioning with anti-pollen filter
 Cab rear window.
 Car radio RDS, CD.
 Car radio RDS, CD, MP3 Bluetooth technology.
 External sun visor.
 Extra colour cab: to be specified in the order.
 Heated and electric powered rear view mirrors.
 Long cab for wheelbase >3800mm with interior equipment (seats and beds) on request.
 Remote controlled and centralized closing of doors.
 Roof hatch.
 Rotating lights on top of the cab.
 White engine hood with central mask in IC575 colour.



SERVICE DATA(I)

Engine oil sump and filters	28
Gearbox oil ZF16S2220TO/ZF16S2520TO:	13
Power steering oil.....	18
Cab tipping oil.....	1
Clutch circuit oil.....	0,5
Integral PTO oil.....	3
Intermediate axle with final red. oil.....	27
Rear axle with final red. oil	16
Cooling system water.....	33
Diesel.....	300



INSTRUMENTATION

Dashboard and ergonomic instrument board contain the function buttons and the identification commands.

Indicator lights: engine oil low pressure, alternator charging low, main beam lights, side lights, engine warm-up, rear fog light, hazard lights, tractor turn indicators, trailer turn indicators (if applicable), rotating lights, cab lifted, axles differential locked, differential lock, front brakes air pressure low, rear brakes air pressure low, trailer brakes air pressure low (if applicable), parking brake engaged, splitter (reduction on), slow speeds (1-4/9-12), power take-off on (if applicable) air filters clogged, power steering oil level low, rear view mirrors heated (if applicable), ABS, trailer ABS (if applicable), main steering circuit failure, steering auxiliary circuit failure.

ASTRA Veicoli Industriali

Via Caorsana, 79
 29122 Piacenza (Italy)
 Tel. ++39-523/5431
 Fax ++39-523/59.17.73
 www. astraspa.com

DEALER

Characteristics and equipment are subject to changes without prior notice.

Technical data and general specifications - validity to be checked according to each individual country