

STHP-HD/45



GERVASI

Excellence in technology

STHP-Heavy Duty/45

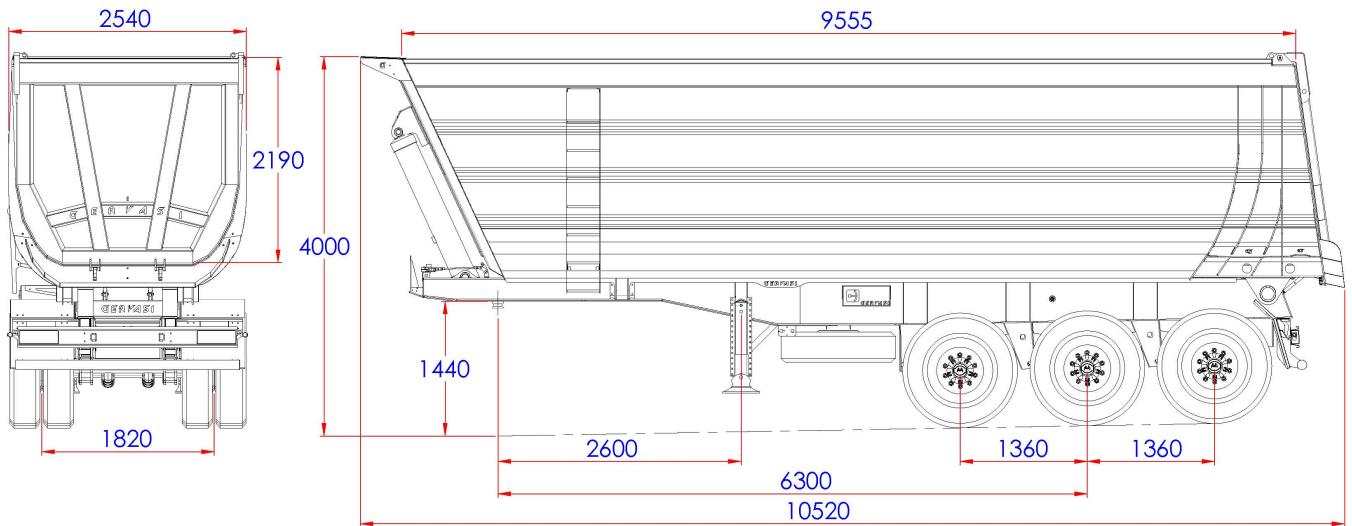

EMPLOY

- Bulk material (sand, gravel, asphalt, bauxite ...).

TIPPER BODY

- Rear tipper body reinforced "ROUND BODY".
- Printed walls in order to give strength and rigidity.
- Fixed side walls.
- Rear gate with automatic mechanical opening upwards.
- Tipping system by telescopic cylinder installed in front position.
- Front board with cab protecting lid and spare wheel housing with winch.
- Rear semi-mudguards.
- Rear protection bar fixed.
- Parking wedges with holders.
- Tool box.
- Lateral ladder.
- Reflectors.
- Water painting:
 - Sandblasting by means of computerized system.
 - Application of acrylic primer and finishing enamel in customer colour.

CHASSIS

- Chassis made in anti-stress steel, suitable for heavy works.
- King pin 3,5"
- N 3 twin axles x 20 ton in tandem with mechanical suspensions
- N 12 + 1 wheels, 12.00 R24 with steel discs
- Brake system with drum brakes.
- Chassis sandblasting by means of computerized system, water painting cycle with primer and water finishing enamel RAL7021 GREY.

BODY VOLUME

TOTAL DEAD WEIGHT OF THE SEMITRAILER

TECHNICALLY PERMISSIBLE TOTAL WEIGHT

KING PIN LOAD

FLOOR

SIDE WALLS

BODY LIFTING ANGLE

45 m³

15000 kg

104700 kg

34000 kg

ST52 Thickness 8 mm

ST52 Thickness 6 mm

45°

DEALER

The dimensions and weights are indicative. They can be changed without warning for manufacturing needs. Gervasi S.p.a.

GERVASI

S.S. 23 del Sestriere km 29 - 10060 Scalenghe (TURIN) Italy

Tel: + 39 011 9866039-529 9866039 Fax: + 39 011 9866750 - www.gervasi-spa.it