

ITALIAN DESIGN  
INTERNATIONAL IMAGE

**STHP/35**



**GERVASI**

Excellence in technology

# SEMITRAILER STHP / 35

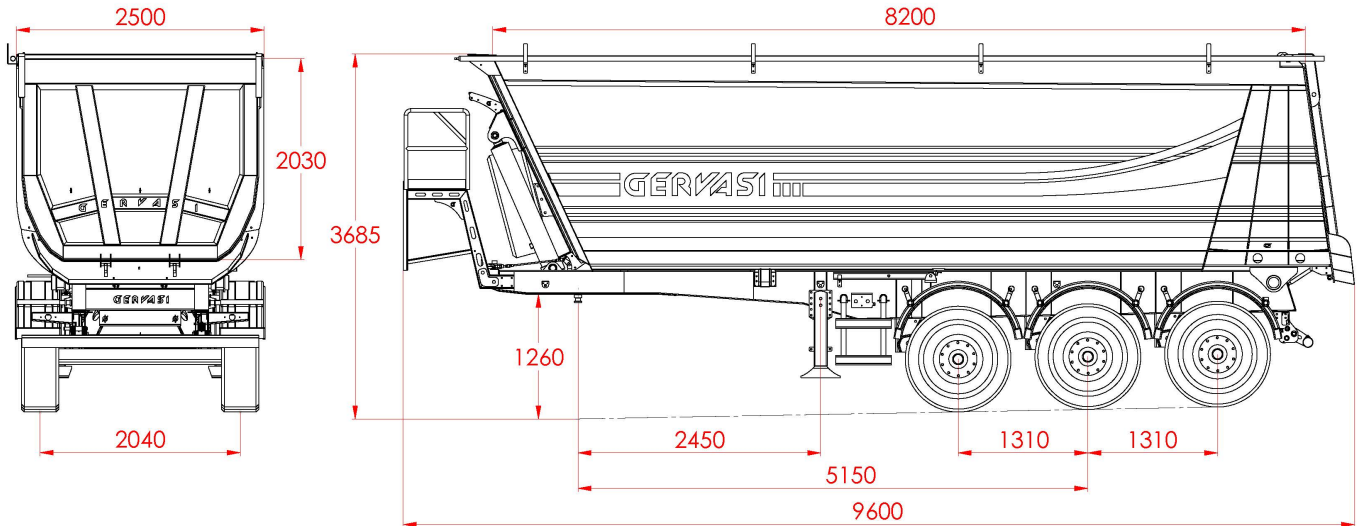

## EMPLOY

- Suitable for the transport of inert materials and excavation (sand, road metal, clayite, asphalt etc.)

## EQUIPMENT

### Sub Frame

- Sub frame in high resistance steel, suitable for heavy works
- No. 3x9 ton fixed axles at pneumatic suspensions
- 6 wheels +1 spare wheel 385/65R 22,5 by leading brands with a kit of steel discs
- Braking system with drum brakes and ABS
- Parking wedges and their holders
- King pin 2"
- Mechanical stabilizer (manual)
- Standard lighting system 24V with back lights
- Fixed side impact protection
- Water Painting cycle:
  - Sandblasting SA 2,5 by means of computerized system
  - Primer and Water Finishing enamel GREY RAL7021

### Tipper Body

- Fixed side walls.
- Rear Gate with automatic mechanic release during tipping
- Tipping system by means of telescopic cylinder mounted in frontal position
- Front gate with cab protection lid and spare-wheel winch
- Tool box
- Rear mudguards
- Rear fixed protection bar
- Rear asphalt extension for finisher
- Side wall
- Reflective strips, Reflective pannels, Marker lights
- Water Painting cycle:
  - Sandblasting SA 2,5 by means of computerized system
  - Acrylic primer and finishing color for Your choice

## OPTIONS

- 1° axle liftable
- Anti-wear steel HB450
- Tarpaulin
- Disc brakes
- King pin 3,5"

<b>BODY VOLUME</b>	<b>35 m<sup>3</sup></b>
<b>SEMITRAILER DEAD WEIGHT</b>	<b>8290 kg</b>
<b>PAYLOAD AT KING PIN</b>	<b>12200 kg</b>
<b>MAX. TECHNICALLY PERMISSIBLE LOAD CAPACITY FLOOR</b>	<b>30710 kg</b>
<b>SIDE WALLS</b>	<b>DOMEX Thickness 6 mm</b>
<b>BODY LIFTING ANGLE</b>	<b>DOMEX Thickness 4 mm</b>
	<b>45°</b>

The dimensions and weights are indicative, they can be changed without warning for manufacturing needs. Gervasi S.p.a.

DEALER



# GERVASI

S.S. 23 del Sestriere km 29 - 10060 Scalenghe (TURIN) Italy  
Tel: + 39 011 9866039 Fax: + 39 011 9866750 - www.gervasi-spa.it