

ITALIAN DESIGN
INTERNATIONAL IMAGE

STHP/33



GERVASI

Excellence in technology

SEMITRAILER STHP / 33

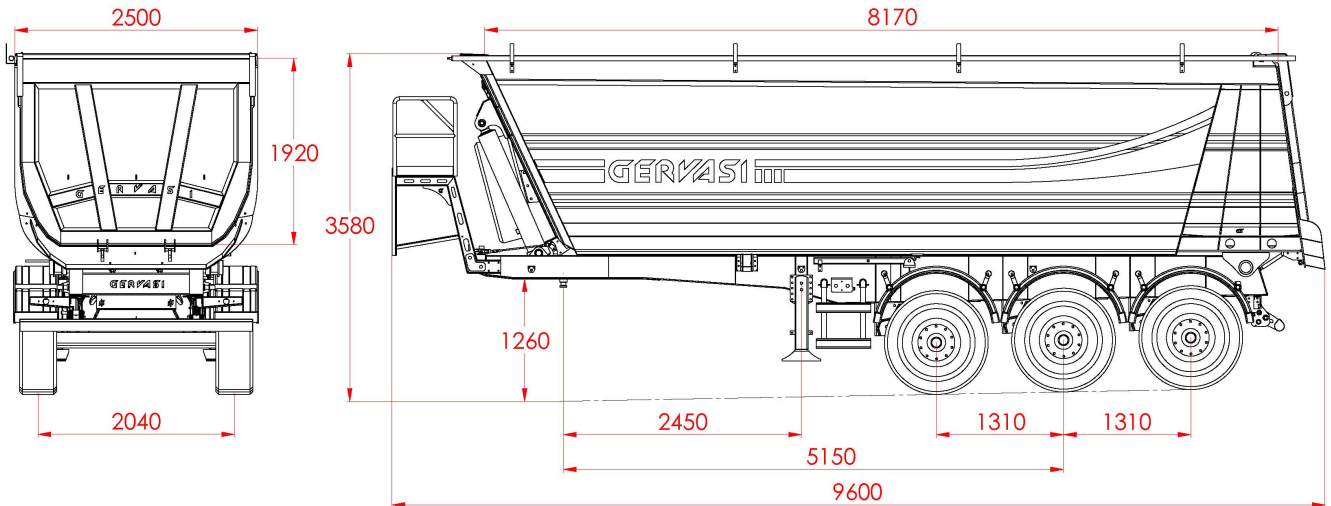

EMPLOY

- Suitable for the transport of inert materials and excavation (sand, road metal, clayite, asphalt etc.)

EQUIPMENT

Sub Frame

- Sub frame in high resistance steel, suitable for heavy works
- No. 3x9 ton fixed axles at pneumatic suspensions
- 6 wheels + 1 spare wheel 385/65R 22,5 by leading brands with a kit of steel discs
- Braking system with drum brakes and ABS
- Parking wedges and their holders
- King pin 2"
- Mechanical stabilizer (manual)
- Standard lighting system 24V with back lights
- Fixed side impact protection
- Water Painting cycle:
 - Sandblasting SA 2,5 by means of computerized system
 - Primer and Water Finishing enamel GREY RAL7021

Tipper Body

- Fixed side walls
- Rear Gate with automatic mechanic release during tipping
- Tipping system by means of telescopic cylinder mounted in frontal position
- Front gate with cab protection lid and spare-wheel winch
- Tool box
- Rear mudguards
- Rear fixed protection bar
- Rear asphalt extension for finisher
- Side wall
- Reflective strips, Reflective pannels, Marker lights
- Water Painting cycle:
 - Sandblasting SA 2,5 by means of computerized system
 - Acrylic primer and finishing color

OPTIONS

- 1° axle liftable
- Anti-wear steel HB450
- Tarpaulin
- Disc brakes
- King pin 3,5"

BODY VOLUME	33 m³
SEMITRAILER DEAD WEIGHT	8170 kg
PAYLOAD AT KING PIN	12200 kg
MAX. TECHNICALLY PERMISSIBLE LOAD CAPACITY FLOOR	30830 kg
SIDE WALLS	DOMEX Thickness 6 mm
BODY LIFTING ANGLE	DOMEX Thickness 4 mm
	45°

The dimensions and weights are indicative. they can be changed without warning for manufacturing needs. Gervasi S.p.a.

DEALER



GERVASI

S.S. 23 del Sestriere km 29 - 10060 Scalenghe (TURIN) Italy
Tel: + 39 011 9866039 Fax: + 39 011 9866750 - www.gervasi-spa.it