

CASE
CONSTRUCTION



F-SERIES WHEEL LOADERS

921F

TIER 2



FAST, PRODUCTIVE, FUEL EFFICIENT

FAST, PRODUCTIVE, FUEL EFFICIENT

Be ready for the best:

- Advanced Engine Technology
- High Efficiency Transmission
- High Productivity Differential and Axles
- Low Maintenance Cooling Design
- Premium Ergonomics



F-SERIES WHEEL LOADERS

921F

TIER 2



ADVANCED ENGINE TECHNOLOGY



New generation engine:

The extremely compact second generation common rail engine delivers top performance in load response, max torque, power and fuel economy.

The combustion is optimized for maximum efficiency, at high temperatures using 100% fresh, cool air, as the air intake is separated from the exhaust.

The turbocharged engine with an Air-to-Air intercooler relies on a 3-step injection technology to maximize responsiveness and fuel efficiency with reduced engine noise and vibrations.

4 working modes (max, economy, normal and auto) allow you to maximize productivity or fuel efficiency according to your needs.

F-SERIES WHEEL LOADERS

921F

TIER 2



10% Lower fuel consumption

The high combustion temperature results in optimum engine performance. The second generation common rail engine ensures better engine control at all rpm. The multiple injection technology delivers optimum combustion control.

Outstanding flat torque

The second generation common rail engine ensures better engine control at all rpm and the 100% fresh air input further improves engine output. The multiple injection technology ensures optimum combustion control, while the 1600 bar injection delivers best-in-class torque performance.

Lower maintenance costs

The combustion chamber and high pressure injection are optimized to reduce oil dilution. The engine only breathes fresh air, so there is no oil contamination. It also has better fuel compatibility because there is no exhaust gas recirculation and it doesn't need a specific oil because with "SCR only" there is no Diesel Particulate Filter.

HIGH PRODUCTIVITY DIFFERENTIAL AND AXLES

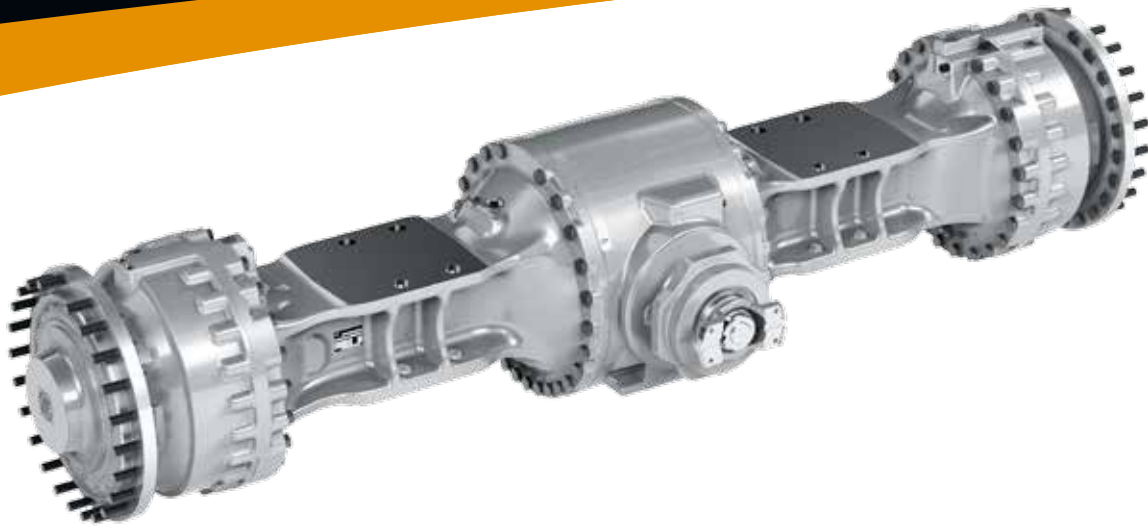

New heavy-duty axles

The new heavy-duty axles are tougher, bigger and easier to service with the 3-piece housing design. Wet multiple disc brakes made of resistant sinter bronze are located in each wheel hub.

Front differential with 100% Auto-lock

With 100% Auto-lock, 100% of the available torque goes to the wheel with adherence, a big step up from the 75% of a limited slip differential! There is no slippage between the wheels and no friction in the differential. The Auto-lock is activated automatically when a front wheel is about to slip, or you can easily do it manually with your left foot.

Open differentials front and rear

With open differentials, no friction is applied to reduce wheel slip, resulting in less wear and lower energy losses.



To reduce your initial investment:

- 921F is also available without 100% auto-lock, suitable for jobs on dry, hard, flat surfaces

F-SERIES WHEEL LOADERS

921F

TIER 2



With L5 tyres, needed for work in very abrasive environments, we recommend heavy-duty axles. Solid tires can be retrofitted

More productivity

100% of available torque is transmitted to the wheels, delivering optimum pushing power.

Greater return on investment

Tyre wear is reduced by 20-30% because there is no slippage between the wheels, fuel consumption is lower because there is no friction in the differential, less maintenance is needed because there are fewer moving components with open differentials. The result: better resale value.

Always reliable

The heavy duty axles and open differentials result in superior reliability.

LOW MAINTENANCE COOLING DESIGN



Better weight distribution with the rear mounted engine

The cooling cube

The unique design, with the five radiators mounted to form a cube instead of overlapping, ensures that each radiator receives fresh air and that clean air enters from the sides and the top, maintaining constant fluid temperatures. The high efficiency of the cooling system lengthens the life of the coolant to 1500 hours.

The standard reversible fan can be activated from the cab and is very effective thanks to the cooling cube

The engine is mounted at the rear of the machine. This, together with the lower fan speed (just 1200 rpm), results in lower noise and vibration levels in the cab.

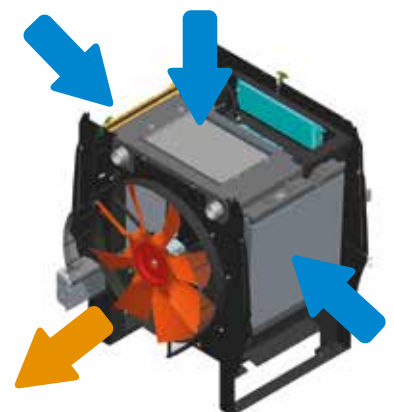

Designed for dusty environment

The cooling system is mounted behind the cab, far from the rear of the machine and from the ground - away from the dust.

F-SERIES WHEEL LOADERS

921F

TIER 2



Less maintenance

The radiators are easy to clean with the reversible fan, which is activated from the cab. The cube design of the cooling system results in more effective cleaning of the radiators, and additional cleaning can be easily done manually, with separate access to each radiator. The efficient cube design also results in a longer life for the cooling fluid, which lasts 500 hours more, so that change intervals are 1500 hours.

Increased reliability

The constant temperature of the fluid maximises its cooling performance and protects the axles, resulting in greater reliability. This is further enhanced by the easy maintenance and longer service intervals. The better weight distribution means that a smaller counterweight or dead weight is needed, which reduces stress on the axles and the brakes.

Upper class bucket payload

Don't be surprised to notice our wheel loader has the same payload as a competitive model of the upper class of weight: this happens because the rear engine position allows to reduce significantly the amount of dead weight in the machine

PREMIUM ERGONOMICS

Protected cab

Our reinforced cab guarantees protection against roll over (ROPS) and falling objects (FOPS)

Low operator vibrations

Engine noise and vibrations are reduced by 3-step injection: pre-, main- and post-injection. To further increase the operator comfort the rear mounted engine is distant from the cab and standard the seat air suspended. Heated seat is optional.

All controls at your fingertips

Outstanding all-round visibility

You'll feel more confident and work faster with the great all-round visibility provided by the very low shape of the curved rear hood and the ample glazed surfaces. 17 air vents ensure your comfort and prevent the windshields from steaming up.

Hydraulic functions that add to your comfort

To maximise your focus on the job and reduce your stress levels, you can activate the following functions from the ergonomically positioned control panel under your right hand:

- Auto-shift : ensures the machine always operates in the most suitable gear according to speed, kick down and engine braking
- Reverse button on the joystick: activates front, neutral or reverse
- Return to dig : brings back the bucket in the right position for loading again
- Return to travel : lowers the boom to carry position, which can be adjusted
- Auto-lift : lifts the boom to the max height you have set
- Auto-Ride Control: reduces loader arm bounce during travel, maintaining maximum material retention. It activates from 8 km/h
- Auto-diff lock : The 100% differential lock can be activated manually with your left foot or automatically for greater focus on the job
- Auxiliary circuit lever: For hydraulic attachments such as high tip bucket, you can order the optional auxiliary circuit controlled by a lever next to the joystick for your ease of use.

Joystick steering

Long days of repetitive cycles go faster with joystick steering (optional) because your sitting position is better.

The steering wheel is maintained for a better handling. You will appreciate it during transfers on uneven terrains, on a descending slope and in case of emergency

Levers controls

Depending on your habits you may prefer the optional 2-lever control to the standard joystick control. The optional 3rd lever controls the attachment auxiliary circuit. It can also be retrofitted as a kit.



F-SERIES WHEEL LOADERS

921F

TIER 2



FAST AND EASY MAINTENANCE

One-piece electric hood

The positioning of the engine at the rear and the easy-to-open electric hood ensure fast access to the service points. Jumper cables are available as standard for jump starting the engine if the battery is low.

Ground level maintenance design

Don't be surprised if you don't see any safety handrails around the hood or steps behind the rear wheels, all service points are easily accessible at ground level. You can do a fast visual check of the hydraulic and transmission oil levels. The three drains are grouped together on the left side, below the hood and battery switches, so that fluids are easy and quick to replace.

Less maintenance, more uptime

You can maximise the working time with these wheel loaders, with the long service intervals of 1500 hours for the transmission oil and filter, the axle oil and filter, and the coolant. The positioning of the cooling system behind the cab means that it needs less cleaning, and the cooling cube design enables you to clean very efficiently with the reversible fan as well as manually. Both pumps and engine distributions rely on one belt only for faster maintenance

Greater Safety

All the main service points are easily accessible from the ground, so you can carry out your daily maintenance safely and efficiently.



The layout of the components under the hood is optimized and results in easier maintenance.



Hood opening and battery on/off switches. In case of flat battery, hood opening can be done externally with remote jump start



Grouped drains



Only one AdBlue fill is need every 3 fuel fill

F-SERIES WHEEL LOADERS

921F

TIER 2



THE DNA OF YOUR 921F

Productivity (50-meter distance cycle)

Considering: density: 1,8 t/m³, fill factor: 100%, 52 cycles/hour and each hour includes a 5-minute break _____ 210 m³/h or 375 t/h
52 loading cycles/h with standard bucket 4.0 m³ or 7.2 ton

Engine Tier 2

compliant with Tier 2 (EU stage II regulations)

FPT turbocharged engine F4HFA613D with:

- 100% fresh air combustion
- Air to Air intercooler
- Multiple injections similar to multi-jet automotive technology to achieve best in class load response, max torque and power with the minimum fuel consumption.

6 cylinders -6,7 liters

Max power SAE J1995 _____ 190kW / 255 hp @1800 rpm

Maximum torque SAE J1349 _____ 1300 Nm @1300 rpm

Transmission

All-wheel drive with planetary axles

kick-down function

4-speed torque converter

4-speed auto Powershift switchable to manual shifting

ZF , switchable to manual shifting

forward speeds _____ 7-12-23-36 Km/h

reverse speeds _____ 7-13-24 Km/h

Adjustable transmission declutch

Axles and differential

For outstanding traction with 50% longer maintenance intervals and 30% less tire wear:

Front and rear ZF Heavy Duty axles with 100% front auto-lock differential. (100% of available torque is always guaranteed on the front wheels)

For standard traction:

Front and rear Heavy Duty axle (ZF type MT-L3095-II)

Open differential front and rear.

Rear axle total oscillation _____ 24°

Tyres

Tyres _____ 23,5R25

Brakes

Service brake _____ Maintenance free,
self-adjusting wet 4-wheel disc brakes

Area _____ 0.47 m²/hub

Parking brake _____ Disc brake on transmission
activated from the cab cluster

Area _____ 82 cm²

Hydraulic

Valves _____ Rexroth Closed-center, Load sensing hydraulic system.

Steering _____ Main valve with 3 sections

The steering orbitrol hydraulically is actuated with priority valve

Type of pump _____ Tandem Variable displacement pump
(282 l/min @2000 rpm)

Automatic hydraulic functions

- Bucket Return-to-dig
- Boom Return-to-travel
- Auto.lift (to adjustable height)

Control type _____ Pilot control with single joystick or two levers

Capacities

Fuel tank _____ 288 usable litres

Cooling system _____ 30 litres

Engine oil _____ 15 litres

Hydraulic oil _____ Tank: 110 litres, total system: 200 litres

Transmission oil _____ 34 litres

Cab and controls

For your safety the cab complies to:

protection against falling objects (FOPS) _____ ISO EN3449

protection against roll over (ROPS) _____ ISO EN13510

Noise and vibration

Driving noise in dB (A) 82 to SAE J88 @ 15 meters

Interior noise _____ 72 LpA as per ISO6595/6396/3744

Exterior noise _____ 71 dB(A) at 15 meters as per SAE J88 SEP80

103 LwA according to ISO6395/6396/3744

Switchable reverse gear alarm

Vibrations _____ air-cushioned seat MSG 95A/732

average 1.4m/s² as per ISO/TR 25398:2006

Electrical system

24V. Batteries 2 x 12V.

Alternator _____ 65A

921F Specifications

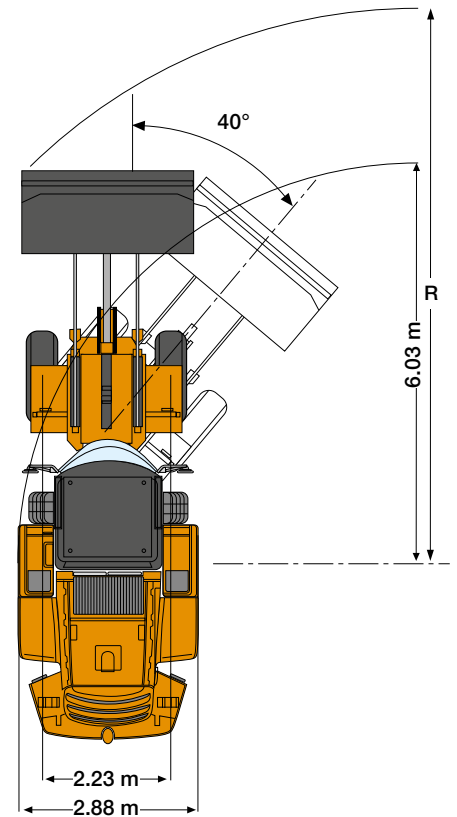
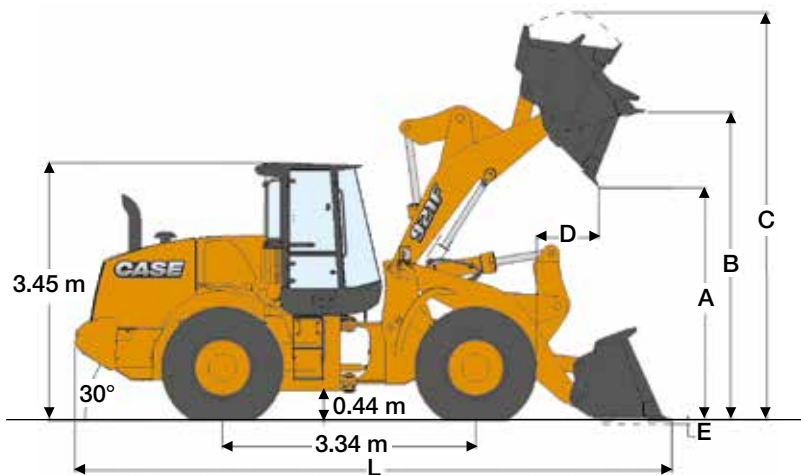

LOADER SPEED

Raising time (loaded)	6.2 sec
Dump time (loaded)	1.4 sec
Lowering time (empty, power down)	3.8 sec
Lowering time (empty, float down)	3.1 sec

921F	Z-BAR buckets		XR buckets (extra reach)		
	3.6 m ³		3.6 m ³		
	Bucket with bolt on:	edge	teeth	edge	teeth
Bucket volume (heaped)	m ³	3.63	3.51	3.63	3.51
Bucket Payload	kg	7123	7233	5649	5737
Maximum material density	tonnes/m ³	2.0	2.1	1.6	1.6
Bucket outside width	m	3.03	3.03	3.03	3.03
Bucket weight	kg	1783	1715	1783	1715
Tipping load - straight	kg	16579	16820	13258	13448
Tipping load - Articulated at 40°	kg	14245	14465	11298	11473
Breakout force	kg	17034	18203	17324	18511
Lift capacity from ground	kg	21148	21739	16527	16685
A - Dump height at 45° at full height	m	2.9	2.81	3.34	3.25
B - Hinge pin height	m	4.12	4.12	4.56	4.56
C - Overall height	m	5.58	5.58	6.02	6.02
D - Bucket reach at full height	m	1.19	1.30	1.3	1.4
E - Dig depth	cm	8	8	14	14
L - Overall length with bucket on the ground	m	7.98	8.12	8.5	8.6
Overall length without bucket	m	6.78	6.78	7.24	7.24
R - Turning radius to front corner of the bucket	m	13.34	13.42	13.85	13.95
Bucket rollback in carry position	°	44	44	43	43
Dump angle at full height	°	47	51	49	49
Machine operating weight	kg	19857	19789	20000	19930

Note: bucket specification can slightly differ according to plant source. More bucket choice is available, please contact your local dealer.



Form No. IR2411CCGB - Printed in Italy - MediaCross Firenze - 09/12



CNH INTERNATIONAL SA
Riva Paradiso, 14
6902 Paradiso
SWITZERLAND



NOTE: Standard and optional fittings can vary according to the demands and specific regulations of each country. The illustrations may include optional rather than standard fittings - consult your Case dealer. Furthermore, CNH reserves the right to modify machine specifications without incurring any obligation relating to such changes.

Conforms to directive 2006/42/EC **CE**



www.casece.com