

- **EXCELLENT RESPONSE TO LOADS:**
Turbo engine on SR150
- **BEST-IN-CLASS DUMP HEIGHT AND DUMP ANGLE:**
fast and efficient material dump
- **SUPERIOR CAB ROOMINESS AND COMFORT:** flat floor, large windows, easy cab access
- **EXCELLENT 360° VISIBILITY:** large windows, good visibility on bucket cutting edge, convenient rear visibility



Specifications SR130

Performance Specs

Rated Operating Capacity 50%	590 kg
ROC with counterweights 50%	635 kg
Tipping Load	1179 kg
Lift Cylinder Breakout Force	19.0 kN
Bucket Cylinder Breakout Force	18.5 kN

Engine

Displacement	2.0 l
Horsepower	46 hp @ 2.900 rpm
Peak torque	130.5 Nm @ 1.750 rpm
Aspiration type	Natural Aspirated

Travel Speed

Low Range	10.8 km/h
High Range (Optional)	NA

Hydraulic System

Pump flow	59 LPM
Optional high flow	NA
Relief Pressure	207 bar

Weights

Operating Weight	2270 kg
Shipping Weight	2130 kg

Service Capacity

Fuel Tank	60.5 l
-----------	--------

Specifications SR150

Performance Specs

Rated Operating Capacity 50%	680 kg
ROC with counterweights 50%	725 kg
Tipping Load	1361 kg
Lift Cylinder Breakout Force	19.0 kN
Bucket Cylinder Breakout Force	18.5 kN

Engine

Displacement	2.0 l
Horsepower	52 hp @ 2.900 rpm
Peak torque	148 Nm @ 1.750 rpm
Aspiration type	Turbo

Travel Speed

Low Range	10.8 km/h
High Range (Optional)	NA

Hydraulic System

Pump flow	59 LPM
Optional high flow	NA
Relief Pressure	207 bar

Weights

Operating Weight	2400 kg
Shipping Weight	2270 kg

Service Capacity

Fuel Tank	60.5 l
-----------	--------

SKID STEER LOADERS

SR130 | SR150

General dimensions

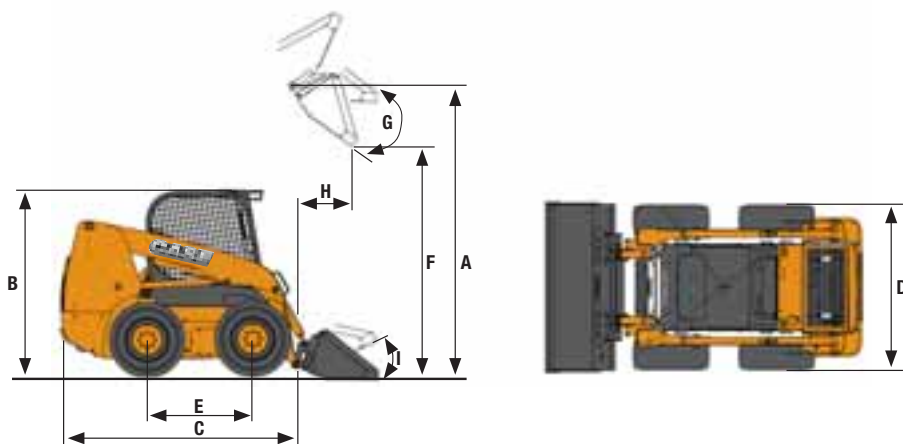

SR130 **SR150**

A Height to Bucket Hinge Pin	2845 mm	2845 mm
B Height to Top of ROPS	1919 mm	1919 mm
C Length without attachment	2435 mm	2435 mm
D Overall Width	1518 mm	1518 mm
E Wheelbase	941 mm	941 mm
F Dump height *	2246 mm	2246 mm
G Dump Angle	40°	40°
H Dump Reach @ Max Height	469 mm	469 mm
I Rollback Angle (Bucket on Ground)	26°	26°

* With D&F Bucket

Many attachments mean many business opportunities



BUCKETS

tailor made bucket for a wide range of applications



PALLET FORKS

easy handling of palletized loads



BROOM BUCKES

efficient surfaces sweeping



HAMMERS

for concrete demolition, trenching and general excavation work



AUGERS

for easy boring of holes in the ground

Check complete list of available attachments on the Parts & Service attachments catalogue

CE

Conforms to directive 2006/42/EC

