

SUNRISE
17 m³



GERVASI

Excellence in technology

SUNRISE

17 m³

3 AXLES, WHEELBASE 3500 MM

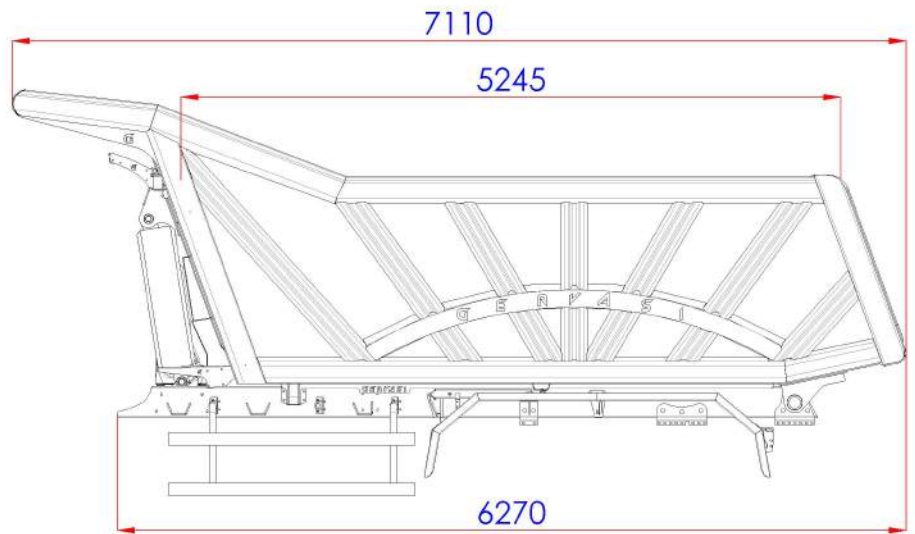
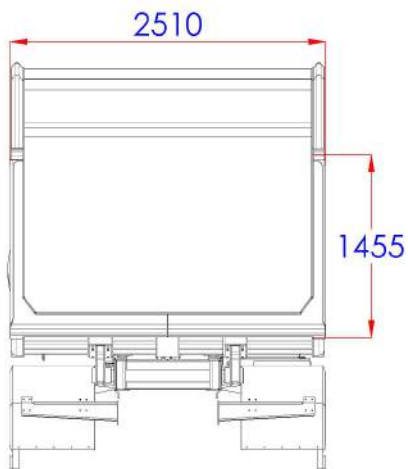

EMPLOY

- Transport of rocks

TIPPER BODY

- Floor tilted upward at rear about 12°
- Fixed side walls with reinforced uprights fashioned and welded continuously
- Rear gate is missing
- Front board with extra long cab protection lid
- Tipping system by means of telescopic cylinder in frontal position
- Pneumatic control of tipping/lowering of the body in the cabin
- Body support
- Water-painting cycle:
 - Sandblasting SA 2,5 by means of computerized system
 - Application of acrylic primer and finishing enamel in Your color RAL
- Rear mudguards
- Tool box
- Side protection bar

OPTIONS

- Parking wedges with holder
- Rear gate
- Lateral clearance lights
- Adhesive reflecting strips
- Reflecting panels
- Floor and side walls of the steel HB450

BODY VOLUME	17 m³
BODY WEIGHT	5400 kg
TOTAL TIPPING STRUCTURE WEIGHT	6450 kg
FLOOR	FE510 thickness 12 mm
SIDE WALLS	FE510 thickness 10 mm
BODY LIFTING ANGLE	50°

The dimensions and weights are indicative. They can be changed without warning for manufacturing needs. Gervasi S.p.A.

DEALER

GERVASI

S.S. 23 del Sestriere km 29 - 10060 Scalenghe (TURIN) Italy
 Tel: + 39 011 9866039-529 9866039 Fax: + 39 011 9866750 - www.gervasi-spa.it