

SUNRISE/26



GERVASI

Excellence in technology

SEMITRAILER SUNRISE / 26

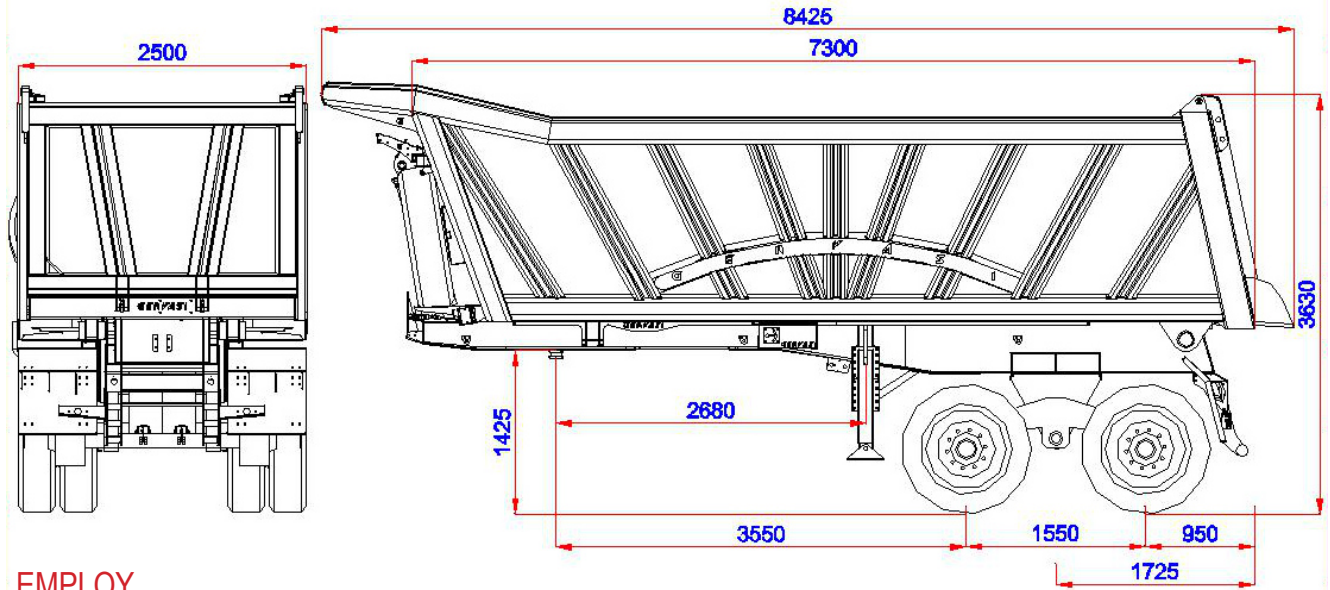

EMPLOY

- Suitable for the transport of rocks.

EQUIPMENT

Sub Frame

- Sub frame in high resistance steel, suitable for rock transport
- No. 2 axles Cantilever at mechanical suspensions
- 8 wheels +1 spare wheel 13.00 R 22,5 by leading brands with steel discs
- Braking system with drum brakes
- Manual mechanical movement stabilizers
- Parking wedges and their holders
- King pin 3,5"
- Standard lighting system 24V with back lights
- Water Painting cycle:
 - Sandblasting SA 2,5 by means of computerized system
 - Primer and Water Finishing enamel GREY RAL7021

Tipper Body

- Walls with reinforcing upwards fashioned and welded continuously
- Fixed side walls
- Rear Gate with automatic mechanic release during tipping
- Tipping system by means of telescopic cylinder mounted in frontal position
- Front gate with cab protection lid and spare-wheel winch
- Tool box
- Rear semi-mudguards
- Rear fixed protection bar
- Reflective pannels
- Water Painting cycle:
 - Sandblasting SA 2,5 by means of computerized system
 - Acrylic primer and finishing color for Your choice

OPTIONS

- Anti-wear steel HB450
- 2nd spare wheel holder

BODY VOLUME

TOTAL DEAD WEIGHT OF THE SEMITRAILER

TECHNICALLY PERMISSIBLE TOTAL WEIGH

USEFUL CHARGE

FLOOR

SIDE WALLS

BODY LIFTING ANGLE

26 m³

5800 kg

39000 kg

4600 kg

ST52 Thickness 12 mm

ST52 Thickness 10 mm

45°

DEALER



The dimensions and weights are indicative, they can be changed without warning for manufacturing needs. Gervasi S.p.a.

GERVASI

S.S. 23 del Sestriere km 29 - 10060 Scalenghe (TURIN) Italy
Tel: + 39 011 9866039 Fax: + 39 011 9866750 - www.gervasi-spa.it