



# HYDRAULIC EXCAVATOR **CX240B**



Engine Horsepower	132 kW - 177 hp
Operating weight (max)	24.5 t
Bucket capacity	0.47 m <sup>3</sup> to 1.43 m <sup>3</sup>

## DIGGING FORCE

Advanced hydraulic system has three working modes offering higher breakout forces, improved swing speeds and greater swing torque, resulting in faster cycle times and 5% increase in productivity. Power boost function is automatically engaged in Auto mode.

Fuel efficient common rail engine meets Tier III emission regulations with reduced fuel consumption and increase in output. Electronic management of speed and power offering lower fuel consumption and productivity benefits.

**Lower fuel costs. Higher machine output.**

## ROBUST DESIGN

Rugged appearance of improved cab and upper structure contribute to high operator satisfaction. Compact four cylinder Tier III engine uses technology from much larger Case machines, to reduce ownership costs and boost productivity.

Exhaust gas recirculation ensures minimum environmental impact.

Cab design provides more space and comfort, reducing operator fatigue over the working day. Advanced engine control system eases operation, with three-mode hydraulic control matching the machine to the application.

**Designed to work. Built to perform.**

## DURABILITY BUILT IN

Redesigned upperstructure to match increased hydraulic performance, ensures legendary Case durability and reliability. Boom and dipper feature forged brackets and reduced tolerances for increased component life and reduced downtime. Resin side shims on boom and dipper contribute to lower wear and longer service intervals. High performance undercarriage components designed to perform in arduous conditions. New synthetic hydraulic filter reduces system contamination, cutting service costs and boosting machine longevity.

**Reduced ownership cost. Increased uptime.**

## PROFITABILITY BONUS

Lower fuel consumption and a 20% increase in fuel tank capacity, result in up to two day work period between refills. High flow electric refuelling pump with auto stop feature as standard. Extended Maintenance System bushes provide 1,000 hour greasing intervals on majority of pins. Green oil drain plugs ease maintenance and provide environmental benefits. Ground access to all filters and best in class service times ensure maximum uptime and reduced ownership and operating costs.  
**Ease of maintenance. Built to keep working.**

☒

## OPERATOR COMFORT

Improved cab structure offers more leg and foot space, with glass surface increase contributing to spacious impression for the operator. Ergonomic layout, intuitive controls, short comfortable joysticks and a seat that lays flat ensures optimum comfort for all operators. Viscous fluid cab mountings and lower internal noise levels contribute to a reduction in stress and fatigue, boosting machine performance. Four position consoles with return to preset on left hand console will suit operators of all sizes.  
**Maximum comfort. Operator satisfaction.**



## SAFETY FIRST

New cab offers larger glass area for improved all round visibility, including single window on right hand side for unobstructed view. Frame structure has three times the structural rigidity of previous model, reducing noise and vibration for the operator. Simple control console with ergonomic design makes it easier to choose the correct operating mode, increasing efficiency and reducing fuel consumption.  
**Improved visibility. Reduced operator fatigue.**

## ENGINE



Low speed four cylinder common rail engine exceeds Tier III emissions standards and ready for Tier IV. Strong engine block and ladder frame construction, with virtually the same weight as previous six cylinder engine, provide extended durability and with low rev cooling fan contribute to 5% lower noise levels. Fuel cooler results in improvement in engine fuel consumption, while exhaust gas recirculation (EGR) reduces gaseous emissions. Radiators and coolers mounted side by side for improved cooling, while large diameter low speed fan contributes to lower noise levels. Auto and one-touch idle speed control for greater operator control.

## HYDRAULICS



Hydraulic pump torque variable control system, maintains optimum engine rpm during heavy load work. Control rapidly reacts to demand, resulting in fuel saving. Hydraulic system uses improved piston pumps with tighter tolerances, reducing system losses and contributing with the new swing relief system into important fuel saving. Revised hose burst control valves mounted behind the main lift cylinders, for maximum safety. Synthetic fibre Super Fine full flow hydraulic filter offers high contamination catching performance, with no need for additional filter when using hydraulic breakers.

## RH CONSOLE, ENGINE THROTTLE



Easy to read console has centralised switch layout for ease of use and luminosity sensor to ensure that graphics can be read in any light conditions. Advanced engine throttle control determines working mode selection, with Power Boost always on in Auto mode. Fully adjustable consoles house short lever joysticks, that are comfortable and improve machine controllability. Machine versatility further improved, as up to 10 auxiliary hydraulic flow settings are programmed into the CX240B's memory. This allows up to 10 attachments to be used with no manual adjustment to hydraulic circuit. Operator can change between hydraulic attachment settings from within the cab.

## OPERATOR'S CAB

Improved cab has reduced width pillars and 60% more glass, including single piece window on right hand side, for great improvement in all round visibility. Structure is 30% stronger, which with viscous fluid cab mounts results in lower noise and vibration, reducing operator fatigue. Four positions for consoles and return to preset on left hand console. Standard air conditioning with nine outlet louvres, along with longer seat slides, a fully reclining seat and more foot space, ensure that operators of any size can get comfortable. Cup holders, clock, mobile phone holder, built-in coolbox and numerous storage compartments for ease of day to day living.



## MAINTENANCE



All filters can be accessed from ground level in centralised position, reducing regular service time. Fuel tank has drain cock and removable maintenance plate, making it easier to clean out in case of contamination. High flow refuelling pump, twice as fast as previous model, has auto stop function to make refilling faster; further reducing downtime. Green engine oil drainer helps reduce environmental impact. Centralised electrics positioned within the cab, behind the operator's seat, to ensure cleanliness and dry operating conditions.

## UNDERCARRIAGE



Track components are designed for extended durability. Case sprockets are heat treated for longer service life. Durability of track guides and track links has been further improved, with new M shaped seals and increased pin hardness extending operating hours and boosting the Case reputation for robust durable design. Track rollers have revised shape and design for less wear, with an improved O-ring design extending service life.

## IMPROVED PIN AND BUSHING LIFE



Extended Maintenance Bushings (EMS) fitted as standard on all CXB machines (only on machines above the CX330 previously). EMS bushings provide 1,000 hour greasing intervals on all but bucket linkage, which retains 250 hour intervals. Anti-friction shims at boom foot and head limit friction and noise in operation and cut free play, increasing durability and reliability and reducing ownership costs.

EMS chrome plated pins with brass bushing

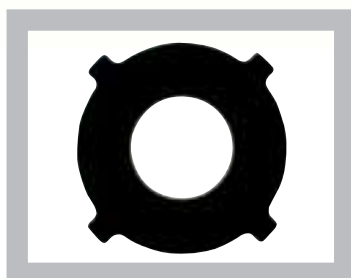

Antifriction shims



## **ATTACHMENTS/BUCKETS**

CX240B customers can choose from a variety of main booms and dipper arms to suit different applications, all of which are constructed of heavy duty steel box section with internal baffles to increase torsional rigidity. Deep groove welding ensures that the booms and arms can withstand the stress of high breakout forces, heavy lifting and attachments such as hydraulic breakers, compactors, demolition shears and crushers. With a different choice of booms and dipper sticks, along with a range of buckets from 0.47m<sup>3</sup> - 1.43 m<sup>3</sup>, there is a configuration to meet the requirements of every customer's job site.





# SPECIFICATIONS

## ENGINE

Latest generation engine, meeting European requirements for "Low exhaust emissions" Tier III in accordance with directive 97/68/EC

Make \_\_\_\_\_ ISUZU  
 Type \_\_\_\_\_ AH-4HK1X  
 Common rail, turbo, intercooler, fuel coolerGR (Exhaust Gas Recirculator) \_\_\_\_\_ Yes  
 Direct injection \_\_\_\_\_ Electronically controlled  
 Number of cylinders \_\_\_\_\_ 4  
 Bore - Stroke \_\_\_\_\_ 115 x 125 mm  
 Cubic capacity \_\_\_\_\_ 5193 cc  
 Horsepower EEC80/1269 \_\_\_\_ 132 kW/177 hp @ 2000 rpm  
 Maximum Torque \_\_\_\_\_ 636 Nm @ 1500 rpm

## HYDRAULIC SYSTEM

Max output \_\_\_\_\_ 2 x 234 l/min @ 2000 rpm  
 2 axial piston, variable flow pumps \_\_\_\_\_ Yes  
 Attachment/Power Boost \_\_\_\_\_ 343/368 bar  
 Upperstructure swing \_\_\_\_\_ 289 bar  
 Travel \_\_\_\_\_ 343 bar  
 Oil filtration \_\_\_\_\_ 6 micron  
 Type of oil filter \_\_\_\_\_ Synthetic fiber Super fine High catch

## SWING

Max upperstructure swing speed \_\_\_\_\_ 10.7 rpm  
 Swing torque \_\_\_\_\_ 7490 daN

## TRAVEL

The travel circuit is equipped with axial piston, variable flow motors

Max travel speed \_\_\_\_\_ 5.5 km/h  
 Low travel speed \_\_\_\_\_ 3.5 km/h  
 Speed change is controlled from the instrument panel  
 Automatic downshifting \_\_\_\_\_ yes  
 Gradeability \_\_\_\_\_ 70% (35°)  
 Tractive force \_\_\_\_\_ 2013 daN

## ELECTRICAL SYSTEM

Circuit \_\_\_\_\_ 24V  
 Batteries \_\_\_\_\_ 2 X 12V - 92 A/h  
 Circuit equipped with water-proof connectors \_\_\_\_\_ yes  
 Alternator \_\_\_\_\_ 24 V - 50 Amp

## UNDERCARRIAGE

Upper rollers \_\_\_\_\_ 2  
 Lower rollers \_\_\_\_\_ 9  
 Number of track pads \_\_\_\_\_ 51  
 Type of shoes \_\_\_\_\_ Triple grouser  
 Track pad width Standard LC/NLC \_\_\_\_\_ 600 mm  
 Track guard \_\_\_\_\_ Front and 1 central

## CIRCUIT AND COMPONENT CAPACITIES

Fuel tank \_\_\_\_\_ 410 l  
 Hydraulic reservoir LC/NLC \_\_\_\_\_ 147 l  
 Hydraulic system \_\_\_\_\_ 250 l  
 Travel reduction gear (per side) \_\_\_\_\_ 4.5 l  
 Swing reduction gear \_\_\_\_\_ 9.7 l  
 Engine (including filter change) \_\_\_\_\_ 23.1 l  
 Engine cooling system \_\_\_\_\_ 25.2 l

# BUCKETS

## GENERAL PURPOSE

SAE capacity	l	475	640	810	940	1060	1180	1300	1430
Width	mm	600	750	900	1000	1100	1200	1300	1400
Weight	kg	525	560	660	715	725	765	805	840

## HEAVY DUTY

SAE capacity	l	1060	1180	1300	1430
Width	mm	1100	1200	1300	1400
Weight	kg	820	865	905	950

Other types of bucket on application

# GENERAL DIMENSIONS

## WITH 5.85 m STANDARD MONOBOOM

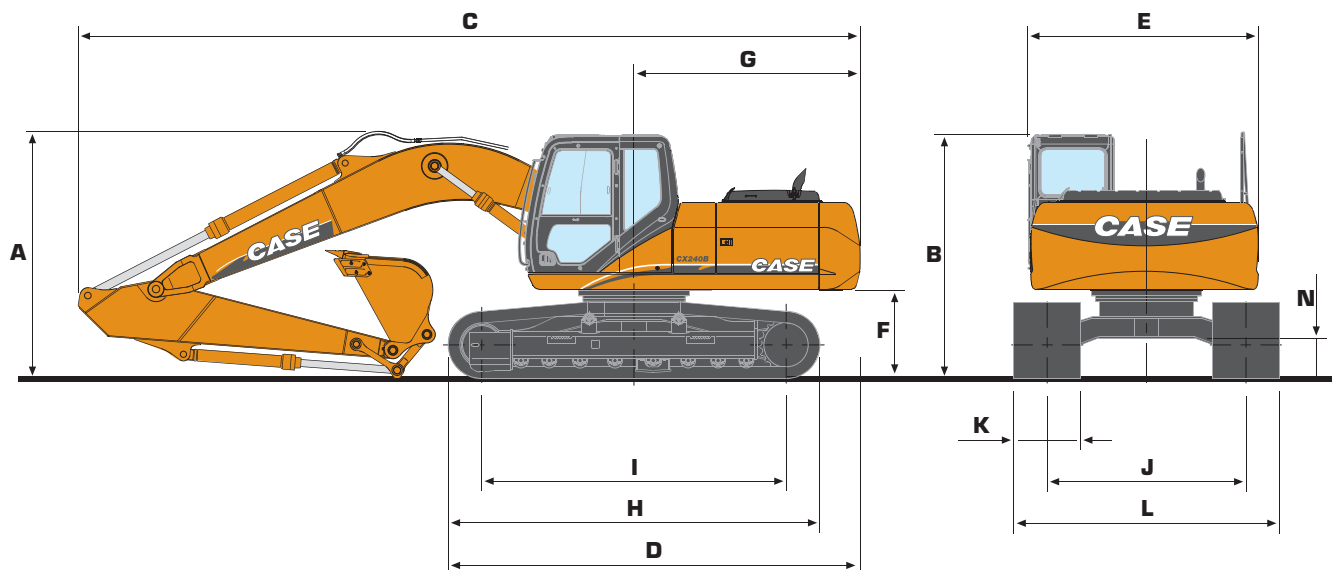

		CX240B LC Mono			CX240B NLC Mono		
		2.50 m	3.00 m	3.52 m	2.50 m	3.00 m	3.52m
<b>DIPPER LENGTH</b>							
<b>A</b> Overall height (with attachment)	m	3.31	3.15	3.31	3.31	3.15	3.31
<b>B</b> Height (cab/handrail)	m	3.00/3.02	3.00/3.02	3.00/3.02	3.00/3.02	3.00/3.02	3.00/3.02
<b>C</b> Overall length (with attachment)	m	9.98	9.93	9.91	9.98	9.93	9.91
<b>D</b> Overall length (without attachment)	m	5.27	5.27	5.27	5.27	5.27	5.27
<b>E</b> Width of upperstructure	m	2.77	2.77	2.77	2.77	2.77	2.77
<b>F</b> Upperstructure ground clearance	m	1.10	1.10	1.10	1.10	1.10	1.10
<b>G</b> Swing radius (rear end)	m	2.94	2.94	2.94	2.94	2.94	2.94
<b>H</b> Track overall length	m	4.65	4.65	4.65	4.65	4.65	4.65
<b>I</b> Centre idler to centre sprocket	m	3.84	3.84	3.84	3.84	3.84	3.84
<b>J</b> Track gauge	m	2.59	2.59	2.59	2.39	2.39	2.39
<b>K</b> Track shoe width standard	mm	600	600	600	600	600	600
<b>L</b> Track overall width - 600mm shoes	m	3.19	3.19	3.19	2.99	2.99	2.99
- 700mm shoes	m	3.29	3.29	3.29	-	-	-
- 800mm shoes	m	3.39	3.39	3.39	-	-	-
<b>N</b> Ground clearance	m	0.46	0.46	0.46	0.46	0.46	0.46

## WEIGHT AND GROUND PRESSURE

With 5.85 m standard monoboomb 3.00 m dipper - 810 kg, 1.1 m<sup>3</sup> bucket, operator and full fuel tank

	WEIGHT (kg)		GROUND PRESSURE (bar)	
	LC	NLC	LC	NLC
shoes 600mm steel	24 500	24 500	0.48	0.48
shoes 700mm steel	24 800	-	0.42	-
shoes 800mm steel	25 100	-	0.37	-

# MONOBOOMB

# PERFORMANCE DATA

WITH 5.85 m STANDARD MONOBOOM - 3.00 m DIPPER

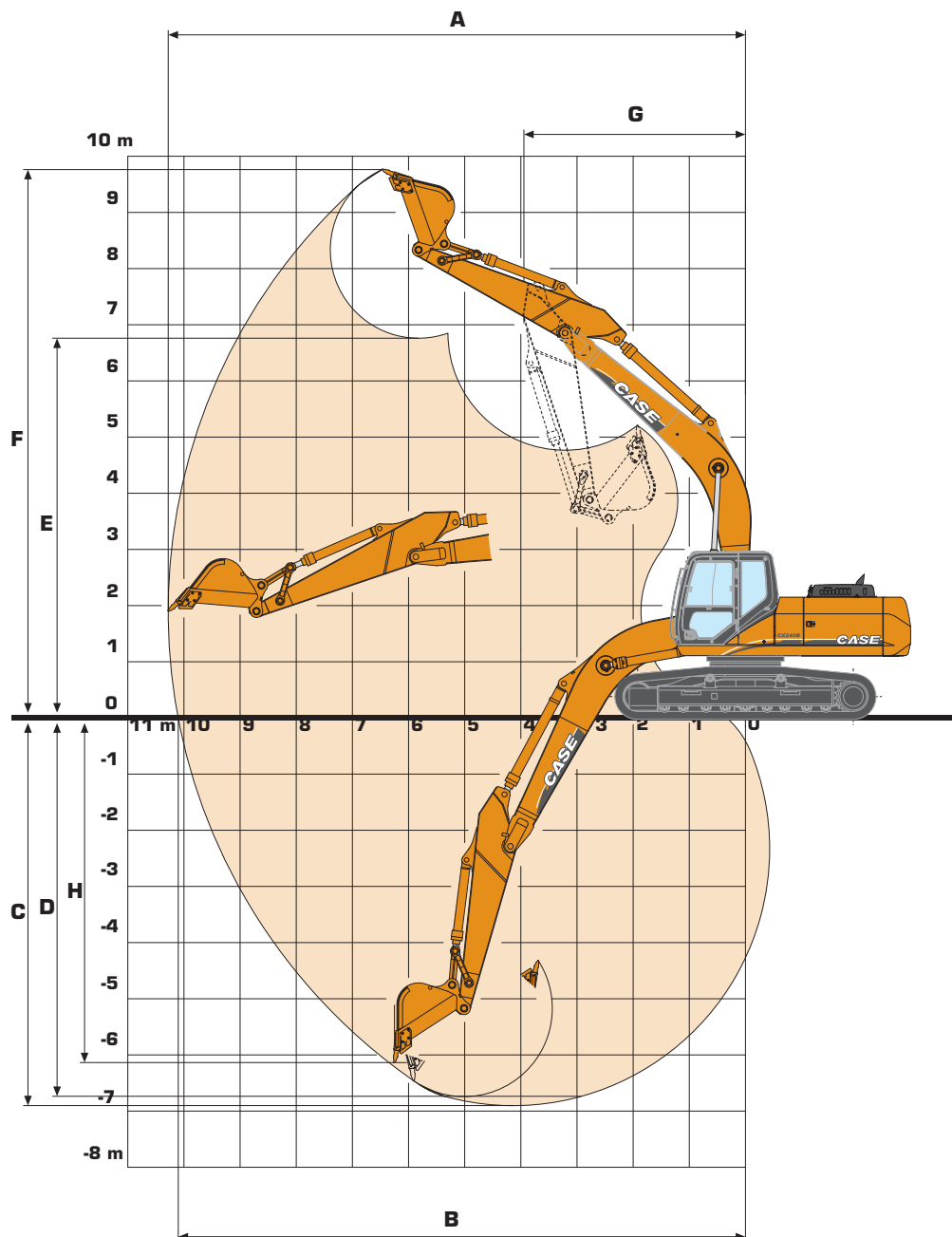

## DIPPER LENGTH

		2.50 m	3.00 m	3.52 m	
<b>A</b>	Maximum digging reach	m	9.82	10.28	10.79
<b>B</b>	Maximum digging reach at ground level	m	9.63	10.10	10.62
<b>C</b>	Maximum digging depth	m	6.40	6.90	7.42
<b>D</b>	Digging depth - 2.44 m level bottom	m	6.21	6.74	7.27
<b>E</b>	Max dump height	m	6.55	6.76	7.06
<b>F</b>	Overall reach height	m	9.56	9.76	10.07
<b>G</b>	Minimum swing radius - attachment	m	3.98	3.95	3.95
<b>H</b>	Vertical straight wall dig depth	m	5.70	6.14	6.68
	Digging force				
	- w/o Power Boost	daN	14 100	12 000	10 700
	- with Power Boost	daN	15 100	12 900	11 500
	Breakout force				
	- w/o Power Boost	daN	16 200	16 200	16 200
	- with Power Boost	daN	17 400	17 400	17 400

# CX240B

# LIFTING CAPACITY

## WITH 5.85 m STANDARD MONOBOOM

Values are expressed in kilos

Front 360°	REACH						m
	3.0 m	4.5 m	6 m	7.5 m	9.0 m	At max reach	

### LC with 3.52 m dipper, 600 mm shoes and bucket of 1.0 m<sup>3</sup> - 790 kg

7.5 m											2576*	2576*	7.41
6.0 m							4353*	4317			2447*	2447*	8.34
4.5 m							5158*	4169			2442*	2442*	8.93
3.0 m			8204*	8204*	6576*	5771	5750*	3955	3522*	2831	2540*	2540*	9.24
1.5 m	11 484*	11 484*	10 604*	8395	7810*	5351	5850	3730	4138*	2719	2751*	2562	9.30
0 m	10 114*	10 114*	12 270*	7814	8091	5021	5644	3542	3753*	2627	3116*	2575	9.11
-1.5 m	12 677*	12 677*	12 931	7549	7875	4830	5521	3429			3742*	2751	8.65
-3 m	16 904*	15 468	12 705*	7512	7820	4782	5511	3421			4922*	3180	7.89
-4.5 m	16 495*	15 838	11 388*	7667	7947	4893					6673	4158	6.72
-6 m	11 758*	11 758*	8095*	8095*							7389*	7263	4.83

### LC with 3.00 m dipper, 600 mm shoes and bucket of 1.1 m<sup>3</sup> - 806 kg

7.5 m											3182*	3182*	6.72
6.0 m							3906*	3906*			3039*	3039*	7.74
4.5 m					6046*	6046*	5630*	4127			3062*	3062*	8.37
3.0 m	14 604*	14 604*	9149*	9037	7142*	5690	6064	3931			3221*	3018	8.70
1.5 m	8696*	8696*	11 366*	8238	8283*	5301	5841	3727			3538*	2873	8.76
0 m	9984*	9984*	12 711*	7766	8078	5017	5666	3567			4087*	2900	8.56
-1.5 m	13 767*	13 767*	12 970	7591	7916	4873	5580	3489			4995	3131	8.08
-3 m	18 165*	15 702	12 466*	7623	7918	4875					5913	3703	7.25
-4.5 m	15 129*	15 129*	10 676*	7851							7719*	5130	5.95

### LC with 2.50 m dipper, 600 mm shoes and bucket of 1.3 m<sup>3</sup> - 868 kg

6.0 m											4446*	4466*	7.20
4.5 m					6592*	5992	6063*	4072			4521*	3716	7.88
3.0 m			10 003*	8832	7638*	5615	6026	3899			4806*	3318	8.23
1.5 m			12 012*	8113	8350	5261	5830	3720			4959	3159	8.29
0 m	9259*	9259*	13 017*	7748	8077	5020	5688	3590			5074	3207	8.08
-1.5 m	14 867*	14 867*	13 026*	7655	7967	4923	5646	3552			5575	3510	7.56
-3 m	17 127*	15 976	12 095*	7750	8029	4977					6810	4273	6.68
-4.5 m	13 537*	13 537*	9742*	8061							8200*	6402	5.23

### NLC with 3.52 m dipper, 600 mm shoes and bucket of 1.0 m<sup>3</sup> - 790 kg

7.5 m											2576*	2576*	7.41
6.0 m							4353*	3943			2447*	2447*	8.34
4.5 m							5158*	3797			2442*	2442*	8.93
3.0 m			8204*	8204*	6576*	5248	5750*	3587	3522*	2550	2540*	2417	9.24
1.5 m	11 484*	11 484*	10 604*	7547	7810*	4836	5832	3365	4138*	2438	2751*	2294	9.30
0 m	10 114*	10 114*	12 270*	6984	8066	4514	5626	3181	3753*	2348	3116*	2301	9.11
-1.5 m	12 677*	12 677*	12 892	6726	7850	4327	5502	3070			3742*	2457	8.65
-3 m	16 904*	13 467	12 705*	6690	7796	4279	5493	3061			4922*	2846	7.89
-4.5 m	16 495*	13 816	11 388*	6841	7922	4389					6651	3733	6.72
-6 m	11 758*	11 758*	8095*	7257							7389*	6524	4.83

### NLC with 3.00 m dipper, 600 mm shoes and bucket of 1.1 m<sup>3</sup> - 806 kg

7.5 m											3182*	3182*	6.72
6.0 m							3906*	3882			3039*	3039*	7.74
4.5 m					6046*	5559	5630*	3757			3062*	3045	8.37
3.0 m	14 604*	14 604*	9149*	8170	7142*	5170	6046	3564			3221*	2723	8.70
1.5 m	8696*	8696*	11 366*	7396	8283*	4790	5823	3364			3538*	2583	8.76
0 m	9984*	9984*	12 711*	6939	8053	4511	5648	3207			4087*	2601	8.56
-1.5 m	13 767*	13 496	12 931	6770	7891	4370	5562	3130			4979	2807	8.08
-3 m	18 165*	13 691	12 466*	6800	7893	4372					5894	3325	7.25
-4.5 m	15 129*	14 122	10 676*	7021							7719*	4616	5.95

### NLC with 2.50 m dipper, 600 mm shoes and bucket of 1.3 m<sup>3</sup> - 868 kg

6.0 m											4446*	4105	7.20
4.5 m					6592*	5466	6063*	3703			4521*	3374	7.88
3.0 m			10 003*	7973	7638*	5097	6008	3534			4806*	2999	8.23
1.5 m			12 012*	7277	8325	4750	5812	3358			4943	2846	8.29
0 m	9259*	9259*	13 017*	6922	8053	4515	5669	3230			5057	2883	8.08
-1.5 m	14 867*	13 696	13 000	6832	7942	4420	5627	3192			5557	3154	7.56
-3 m	17 127*	13 951	12 095*	6925	8004	4473					6789	3845	6.68
-4.5 m	13 537*	13 537*	9742*	7226							8200*	5763	5.23

Machine in Auto mode

Lift capacities are taken in accordance with SAE J1097/ISO 10567/DIN 15019-2

Lift capacities shown in kg do not exceed 75% of the tipping load or 87% of the hydraulic lift capacity

Capacities that are marked with an asterisk (\*) are hydraulic limited

If the machine is equipped with a quick coupler, subtract the weight of the quick coupler from the load shown in the table to calculate the real lift capacity

# GENERAL DIMENSIONS

WITH 10.30 m LONG REACH BOOM

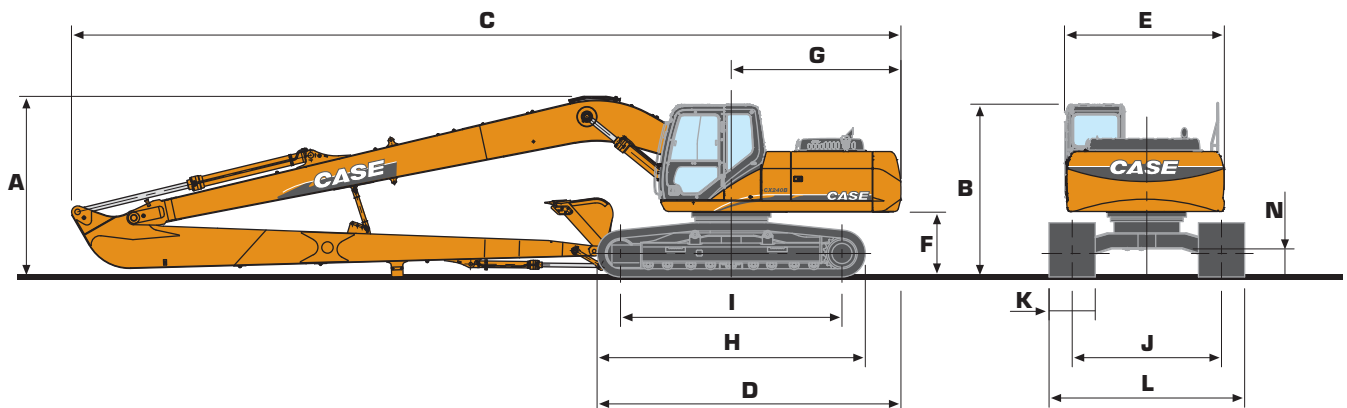

## CX240B LR

### DIPPER LENGTH

8.00 m

<b>A</b>	Overall height (with attachment)	m 3.13
<b>B</b>	Height (cab/handrail)	m 3.00/3.02
<b>C</b>	Overall length (with attachment)	m 14.38
<b>D</b>	Overall length (without attachment)	m 5.27
<b>E</b>	Width of upperstructure	m 2.77
<b>F</b>	Upperstructure ground clearance	m 1.10
<b>G</b>	Swing radius (rear end)	m 2.94
<b>H</b>	Track overall length	m 4.65
<b>I</b>	Centre idler to centre sprocket	m 3.84
<b>J</b>	Track gauge	m 2.59
<b>K</b>	Track shoe width standard	mm 800
<b>L</b>	Track overall width - 800 mm shoes	m 3.39
<b>N</b>	Ground clearance	m 0.46

## WEIGHT AND GROUND PRESSURE

With 10.30 m long reach  
boom 8.00 m dipper  
338 kg, 0.37m<sup>3</sup> bucket  
operator and full fuel tank

	WEIGHT (kg)	GROUND PRESSURE (bar)
--	-------------	-----------------------

shoes 800 mm steel	28 000	0.42
--------------------	--------	------

## BUCKETS

### GENERAL PURPOSE

SAE capacity	l	370	570
Width	mm	600	910

### DITCH

SAE capacity	l	570	670
Width	mm	1520	1680

# LONG REACH

# PERFORMANCE DATA

## WITH 10.30 m LONG REACH BOOM - 8.00 m DIPPER

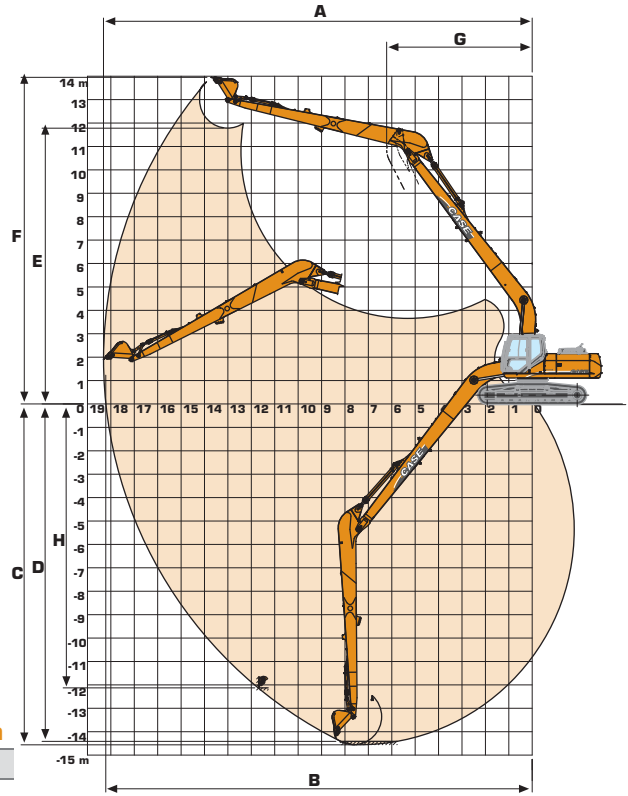

### DIPPER LENGTH

8.00 m

<b>A</b>	Maximum digging reach	m	18.32
<b>B</b>	Maximum digging reach at ground level	m	18.22
<b>C</b>	Maximum digging depth	m	14.56
<b>D</b>	Digging depth - 2,92 m level bottom	m	14.41
<b>E</b>	Max dump height	m	11.78
<b>F</b>	Overall reach height	m	13.95
<b>G</b>	Minimum swing radius - attachment	m	6.22
<b>H</b>	Vertical straight wall dig depth	m	12.19
	Digging force	daN	4400
	Breakout force	daN	7700

# LIFTING CAPACITY

## WITH 10.30 m LONG REACH BOOM

Values are expressed in kilos

Front 360°	REACH											At max reach m
	3.0 m	4.5 m	6.0 m	7.5 m	9.0 m	10.5 m	12.0 m	13.5 m	15 m	16,5 m		

### LR with 8.00 m dipper, 800 mm shoes and bucket of 0.37m³ - 338 kg

10.5 m																					1509*	1509*	13.78													
9.0 m																						1474*	1474*	14.77												
7.5 m																						1463*	1463*	15.55												
6.0 m																						1474*	1413	16.16												
4.5 m																						1834*	1834*	17.23*	1721*	1721*	16.60									
3.0 m																						1723*	1723*	1794*	1665	1609*	1288	1505*	1264	16.60						
1.5 m																						2086*	2086*	1974*	1974*	1893*	1581	1843*	1234	1555*	1150	16.91				
0 m																						2874*	2874*	2541*	2541*	2306*	2306*	2134*	1877	2009*	1487	1922*	1171	1627*	1065	17.07
-1.5 m	2102*	2102*	7167*	7167*	5246*	5246*	4042*	4042*	3327*	3327*	2860*	2758	2537*	2184	2305*	1742	2134*	1391	1915	1105	1724*	1004	1710													
-3.0 m	1685*	1685*	3914*	3914*	6179*	5576	4662*	4133	3758*	3187	3171*	2514	2766*	2008	2475*	1615	2210	1299	1850	1042	1745	967	1700													
-4.5 m	1929*	1929*	3407*	3407*	6591*	5032	5172*	3740	4134*	2903	3451*	2306	2977*	1855	2540	1502	2126	1219	1794	988	1743	953	16.76													
-6.0 m	2336*	2336*	3518*	3518*	5881*	4708	5548*	3470	4433*	2691	3584	2143	2936	1732	2445	1411	2059	1154			1774	963	16.39													
-7.5 m	2815*	2815*	3880*	3880*	5907*	4543	5636	3307	4327	2550	3463	2029	2843	1643	2377	1346	2015	1112			1846	1003	15.86													
-9.0 m	3347*	3347*	4388*	4388*	6306*	4491	5553	3232	4246	2474	3393	1963	2790	1592	2341	1312	2000	1098			1969	1079	15.16													
-10.5 m	3932*	3932*	5017*	5017*	6976*	4525	5550	3229	4228	2457	3374	1945	2778	1582	2343	1314					2166	1206	14.27													
-12.0 m	4579*	4579*	5771*	5771*	7172*	4634	5617	3290	4270	2496	3407	1977	2815	1616							2479	1413	13.15													
	5297*	5297*	6680*	6680*	8645*	4817	5308*	3416	4348*	2594	3500	2064									2999	1761	11.74													
	6090*	6090*	7497*	7497*	9814*	5087	5670*	3620	4381*	2766											3352*	2417	9.90													
					4507*	4507*																3686*	3686*	7.32												

Machine in Auto mode Lift capacities are taken in accordance with SAE J1097/ISO 10567/DIN 15019-2 Lift capacities shown in kg do not exceed 75% of the tipping load or 87% of the hydraulic lift capacity Capacities that are marked with an asterisk (\*) are hydraulic limited. If the machine is equipped with a quick coupler, subtract the weight of the quick coupler from the load shown in the table to calculate the real lift capacity

# CX240B

## STANDARD EQUIPMENT & OPTIONS

### STANDARD EQUIPMENT

#### Engine control

- Common rail engine Tier III European Standards
- Electronic control of the injection system
- Automatic engine pre-heating
- Automatic/manual engine return to idle
- Exhaust Gas Recirculator
- Emergency stop
- Electrical refuel pump with automatic stop
- Fuel filter with water separator

#### Hydraulic control

- Auto/Heavy/Super Power working modes
- Pump torque variable control
- Automatic Power boost control
- Swing brake control
- High performance "Super Fine" synthetic fiber hydraulic filter (high contamination catch)
- Hydraulic safety valves on boom and dipper
- 2 travel speeds with auto down shifting

#### Operator environment

- High visibility cab with safety glass
- Adjustable and retractable armrest console with position memory
- Safety lever
- Self adjusting Air conditioning and heating system
- Cup holder
- High visibility side monitor display with automatic brightness
- Messages (function, temperature, safety, ...) on the display
- Integrated diagnostic system
- Working modes (Auto/Heavy/Super Power) combined with engine throttle
- Anti-theft device
- Hourmeter
- Selectable auxiliary hydraulic flow pre-settings
- RH front console with clock and cell phone holder
- High capacity shock absorbers on cab with 4 points fluid mountings
- Rain deflector
- Windscreen with lockable opening
- Windscreen washer and wiper
- Removable lower front windscreen with storage location in cab
- Glass cab roof window and sliding sun shade
- ISO control pattern low effort & short joysticks
- Adjustable sun visor

- Washable cab floor mat
- Rear view mirror and safety mirrors
- Storage compartments
- Integrated cool box
- 12V and 24V DC accessory sockets
- Hammer/Shear change selected from the cab
- Fore & aft adjustment of the whole seat & console

#### Electrical system

- Water proof connectors
- Double horn
- 2 working light on the cab
- Working light on the fuel tank
- Working light on the boom

#### Equipment

- EMS (Extended Maintenance System) pins and bushings as Standard (1000 hours lubrication interval for all, except buckets pins at 250 hours)
- Low friction resin side shims on boom and dipper
- Sealed and lubricated tracks
- Track guides (1 guide & front)
- Large tool box
- Pre-disposal for the optional cab protection

#### Operator seat

- Fully adjustable low frequency air suspension seat including double acting hydraulic damper
- Adjustable head rest
- Adjustable seat back angle with fully flat seat reclining
- Adjustable arm rest
- Adjustable lombar position
- Height/fore & aft adjustment
- Safety belt

### OPTIONS

- Bucket/clamshell hydraulic circuit
- Hammer hydraulic circuit
- Hammer/shear hydraulic circuit
- Additional track guides (3 guides & front instead of 1 guide & front)
- Track width (600mm - 700mm - 800mm depending on the version)
- Windscreen protection
- Cab protection
- GPS (Global Positioning System) by satellite
- Centralized greasing system automatically actuated by an electrical grease pump

Standard and optional equipment shown can vary by country.



CNH INTERNATIONAL SA  
Riva Paradiso, 14  
6902 Paradiso  
SWITZERLAND

**NOTE:** Standard and optional fittings can vary according to the demands and specific regulations of each country. The illustrations may include optional rather than standard fittings - consult your Case dealer. Furthermore, CNH reserves the right to modify machine specifications without incurring any obligation relating to such changes.



Conforms to directive 98/37/CE

[www.casece.com](http://www.casece.com)

**CASE**  
CONSTRUCTION