

CASE

CONSTRUCTION

HYDRAULIC EXCAVATOR **CX210B**



Engine Horsepower	117 kW - 157 hp
Operating weight	21.3 t
Bucket capacity	0.25 m ³ to 1.25 m ³

MAXIMUM EFFICIENCY HYDRAULICS

Three working modes tailor the machine to every application. Advanced Auto mode and Super Power mode offer increased digging forces, greater swing speeds and higher swing torque, resulting in faster cycle times and increased productivity. Fuel efficient Tier III common rail engine combined with high efficiency hydraulic system results in up to 20 % fuel saving.

Reduced operating costs. Increased productivity.

DESIGNED TO PERFORM

Strong, rugged looks of new cab and upper structure contribute to increased operator satisfaction. New Tier III engine uses technology from much larger machines, to increase performance while reducing running costs. Advanced control system makes the CX210B easier to drive, reducing fatigue and boosting production, while exhaust gas recirculation and advanced common rail injection lower emissions, reducing the impact on the environment.

**Cleaner emissions.
Tough performance.**

BUILT TO WORK

Case durability throughout, with redesigned upper structure and new boom and dipper design with forged brackets. EMS bushes increase durability and reduce servicing costs, keeping the machine working in the most arduous conditions. High performance hydraulic filter increases component life and extends maintenance schedules.

Minimal downtime. Maximum productivity.

LOWER OPERATING COSTS

A 20 % larger fuel tank, combined with lower fuel consumption, results in two day work period between refills. Standard high flow electric refuelling pump with auto stop feature twice as fast as current model. Extended Maintenance System bushes offer 1,000 hour greasing intervals on all pins but the bucket. Side by side coolers easy to maintain and ground access centralised filter bank reduces service time.

Reduced running costs. Increased profitability.



OPERATOR COMFORT

New cab structure and layout offers more leg and foot space for operator, while more glass contributes to airy feeling in the cab. Fully reclining seat allows any operator to remain comfortable throughout the day and increased storage, including hot/cold box, improves working space. Smooth servo levers with intuitive control reduce fatigue, while advanced throttle control and mode selector makes operation easier.

Low fatigue environment. Increased performance.

SAFE AND SECURE

Cab profile three times stronger than previous model, despite slimmer pillars and increased glass area, which contributes to improved visibility to the front and sides of the machine. Simple working mode console offers smooth, progressive control of the machine whatever the operation.

Clearer vision. Safer working environment.



AWARDED

- October 2007, CX210B is awarded "Good Design Award" by the Design Academy of Japan.
- January 2008, CX210B won the 18th "Energy Conservation Award" by the Agency for Natural Resources and Energy in Ministry of Economy, Trade and Industry and Energy Conservation Centre, Japan.

ENGINE

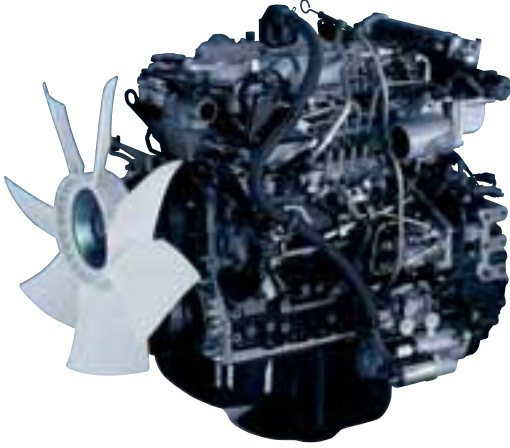

Proven four cylinder common rail engine exceeds Tier 3 emissions standards. Ladder frame construction, with similar weight to a six cylinder engine, results in tough build with extended durability for all components. Low engine speed contributes to 5% lower noise output and 20% improvement in fuel consumption. Large capacity exhaust muffler and low rev, large diameter, engine cooling fan further cut engine noise.

Fuel cooler contributes in engine fuel consumption improvement, while four valve per cylinder overhead camshaft design and exhaust gas recirculation (EGR) reduce gaseous emissions. Future-proof advanced engine design means that Case is already well equipped to meet Euro IV emissions standards.

HYDRAULICS



The CX210B offers further advances in hydraulic design, using efficient piston type pumps to maximise pressure and flow. The machine uses a variable control pump torque system that matches engine output to hydraulic demand, reacting rapidly to operator movement to ensure high productivity.

A high performance Super Fine synthetic fibre hydraulic filter is used to offer a high contamination catch, protecting components and ensuring long service life. There is now no need for an additional filter when the machine is used with a hydraulic breaker. New hose burst control valves are now mounted behind the main lift cylinders, for improved protection.

CONSOLE, ENGINE THROTTLE



Centralised layout of switches is easy to use. Fully adjustable right hand console includes advanced engine throttle control, that determines working mode selection. The console is equipped with a luminosity sensor to ensure that the graphics are clear and easily readable in bright sunlight. Short lever joysticks further improve controllability for the operator.

Up to 10 auxiliary hydraulic flow settings are programmed into the memory, allowing up to 10 attachments to be used with no manual adjustment to hydraulic circuit. The operator can change from breaker to shear setting from within the cab.

OPERATOR'S CAB

New cab has thinner pillars and 60% more glass, including one piece window on right hand side, for improved visibility all round. The main windscreen has a retractable sun visor and can be lifted fully into the roof space if required. The cab structure is 30% stronger, which with improved cab mounts results in lower noise and vibration for the operator. Longer seat slides, a fully reclining seat and foot space, and standard air conditioning with numerous outlet vents ensure that any operator can stay comfortable throughout the working day.

A clock is included while storage is improved, with a large box behind the driver's seat, bottle and can holders and a cool/hot box that uses the air conditioning system to regulate internal temperature.



MAINTENANCE



Centralised filters can be changed from ground level, reducing service time and improving uptime. Fuel tank has drain cock and removable maintenance plate, for cleaning in territories with lower grade fuels. Engine oil drainer helps reduce environmental impact as there is no spillage. All electrics are centralised in the cab, behind the seat, to maintain cleanliness and reduce ingress of dirt. High flow refuelling pump, has auto stop function to make refuelling easier.

UNDERCARRIAGE



Case undercarriage design continues to ensure long component life and low operating costs. Drive sprockets are heat treated for extended operation. The machine has robust track guides and improved track links, with new M shaped seals and increased pin hardness, for maximum durability and reliability. The track rollers use a revised design for less wear, and the O-ring design prevents the ingress of abrasive material, enhancing the Case reputation for class leading longevity.

IMPROVED PIN AND BUSHING LIFE



Extended Maintenance Bushings (EMS) now fitted as standard on all CXB machines. EMS bushings provide 1,000 hour greasing intervals, greatly reducing daily and weekly maintenance for the operator, though bucket link pins retain 250 hour greasing interval. Anti-friction shims at boom foot and head reduce friction and noise in operation, while cutting free plat, increasing durability and reducing cost for the customer.

EMS chrome plated pins with brass bushing



Anti-friction shims



ATTACHMENTS/BUCKETS

CX210B customers can choose from a variety of main booms and dipper arms to suit different applications, all of which are constructed of heavy duty steel box section with internal baffles to increase torsional rigidity. Deep groove welding ensures that the booms and arms can withstand the stress of high breakout forces, heavy lifting and attachments such as hydraulic breakers, compactors, demolition shears and crushers.

With a different choice of booms and dipper sticks, along with a range of buckets from 0.25m³ - 1.25 m³, there is a configuration to meet the requirements of every customer's job site.





SPECIFICATIONS

ENGINE

Latest generation engine, meeting European requirements for "Low exhaust emissions" Tier III in accordance with directive 97/68/EC

Make _____ ISUZU
 Type _____ AI-4HK1X
 Common rail, turbo, intercooler, fuel cooler, EGR (Exhaust Gas Recirculator) _____ Yes
 Direct injection _____ Electronically controlled
 Number of cylinders _____ 4
 Bore - Stroke _____ 115 x 125 mm
 Cubic capacity _____ 5193 cc
 Horsepower EEC80/1269 _____ 117 kW @ 1800 rpm
 Maximum Torque _____ 628 Nm @ 1500 rpm

HYDRAULIC SYSTEM

Max output _____ 2 x 211 l/min @ 1800rpm
 2 axial piston, variable flow pumps _____ Yes
 Attachment/Power Boost _____ 343/368 bar
 Upperstructure swing _____ 294 bar
 Travel _____ 343 bar
 Oil filtration _____ 6 micron
 Type of oil filter _____ Synthetic fiber super fine High catch

SWING

Max upperstructure swing speed _____ 11.5 rpm
 Swing torque _____ 6400 daN

TRAVEL

The travel circuit is equipped with axial piston, variable flow motors
 Max travel speed _____ 5.6 km/h
 Low travel speed _____ 3.4 km/h
 Speed change is controlled from the instrument panel
 Automatic downshifting _____ yes
 Gradeability _____ 70% (35°)
 Tractive force _____ 1892 daN

ELECTRICAL SYSTEM

Circuit _____ 24 V
 Batteries _____ 2 x 12 V - 92 A/h
 Circuit equipped with water-proof connectors _____ Yes
 Alternator _____ 24 V - 50 Amp

UNDERCARRIAGE

Upper rollers _____ 2
 Lower rollers _____ 8
 Number of track pads _____ 49
 Type of shoes _____ Triple grouser
 Track pad width Standard LC/NLC _____ 600 mm/500 mm
 Track guard _____ Front and 1 central

CIRCUIT AND COMPONENT CAPACITIES

Fuel tank LC/NLC _____ 410 l/320 l
 Hydraulic reservoir LC/NLC _____ 147 l/127 l
 Hydraulic system _____ 240 l
 Travel reduction gear (per side) _____ 4.5 l
 Swing reduction gear _____ 5 l
 Engine (including filter change) _____ 23.1 l
 Engine cooling system _____ 25.6 l

BUCKETS

GENERAL PURPOSE

SAE capacity	l	410	560	700	800	900	1050	1150	1250
Width	mm	600	750	900	1000	1100	1250	1350	1450
Weight	kg	554	600	640	670	700	760	790	820

HEAVY DUTY

SAE capacity	l	900	1050	1150
Width	mm	1100	1250	1350
Weight	kg	740	810	840

* For other bucket sizes, please contact your CASE dealer

CX210B

GENERAL DIMENSIONS

WITH 5.70 m STANDARD MONOBOOM

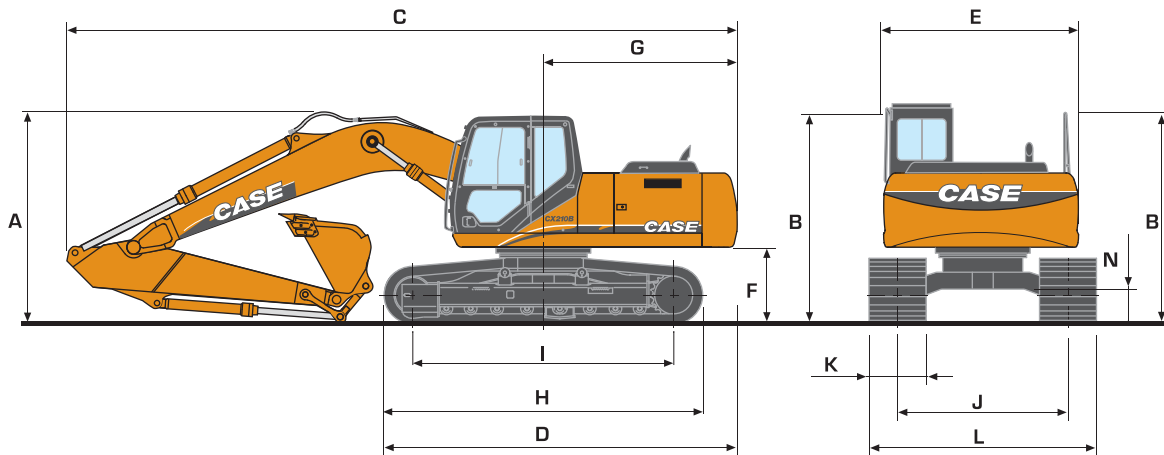

		CX210B LC MONO			CX210B NLC MONO		
		1.90 m	2.40 m	2.94 m	1.90 m	2.40 m	2.94m
DIPPER LENGTH							
A Overall height (with attachment)	m	3.09	3.19	2.97	3.20	3.09	2.97
B Height (cab/handrail)	m	2.94/2.96	2.94/2.96	2.94/2.96	2.97/2.99	2.97/2.99	2.97 /2.99
C Overall length (with attachment)	m	9.40	9.48	9.40	9.59	9.59	9.50
D Overall length (without attachment)	m	4.96	4.96	4.96	5.05	5.05	5.05
E Width of upperstructure	m	2.77	2.77	2.77	2.54	2.54	2.54
F Upperstructure ground clearance	m	1.04	1.04	1.04	1.07	1.07	1.07
G Swing radius (rear end)	m	2.72	2.72	2.72	2.83	2.83	2.83
H Track overall length	m	4.47	4.47	4.47	4.47	4.47	4.47
I Centre idler to centre sprocket	m	3.66	3.66	3.66	3.66	3.66	3.66
J Track gauge	m	2.39	2.39	2.39	1.99	1.99	1.99
K Track shoe width standard	mm	600	600	600	500	500	500
L Track overall width - 500mm shoes	m	-	-	-	2.49	2.49	2.49
- 600mm shoes	m	2.99	2.99	2.99	-	-	-
- 700mm shoes	m	3.09	3.09	3.09	-	-	-
- 800mm shoes	m	3.19	3.19	3.19	-	-	-
N Ground clearance	m	0.46	0.46	0.46	0.46	0.46	0.46

WEIGHT AND GROUND PRESSURE

With 5.70 m standard monoboomb 2.40 m dipper 698 kg, 1m³ bucket operator and full fuel tank

	WEIGHT (kg)		GROUND PRESSURE (bar)	
	LC	NLC	LC	NLC
shoes 500mm steel	-	21 350	-	0.53
shoes 600mm steel	20 900	-	0.43	-
shoes 700mm steel	21 400	-	0.38	-
shoes 800mm steel	21 700	-	0.34	-

MONOBOOMB

PERFORMANCE DATA

WITH 5.70 m STANDARD MONOBOOM - 2.40 m DIPPER

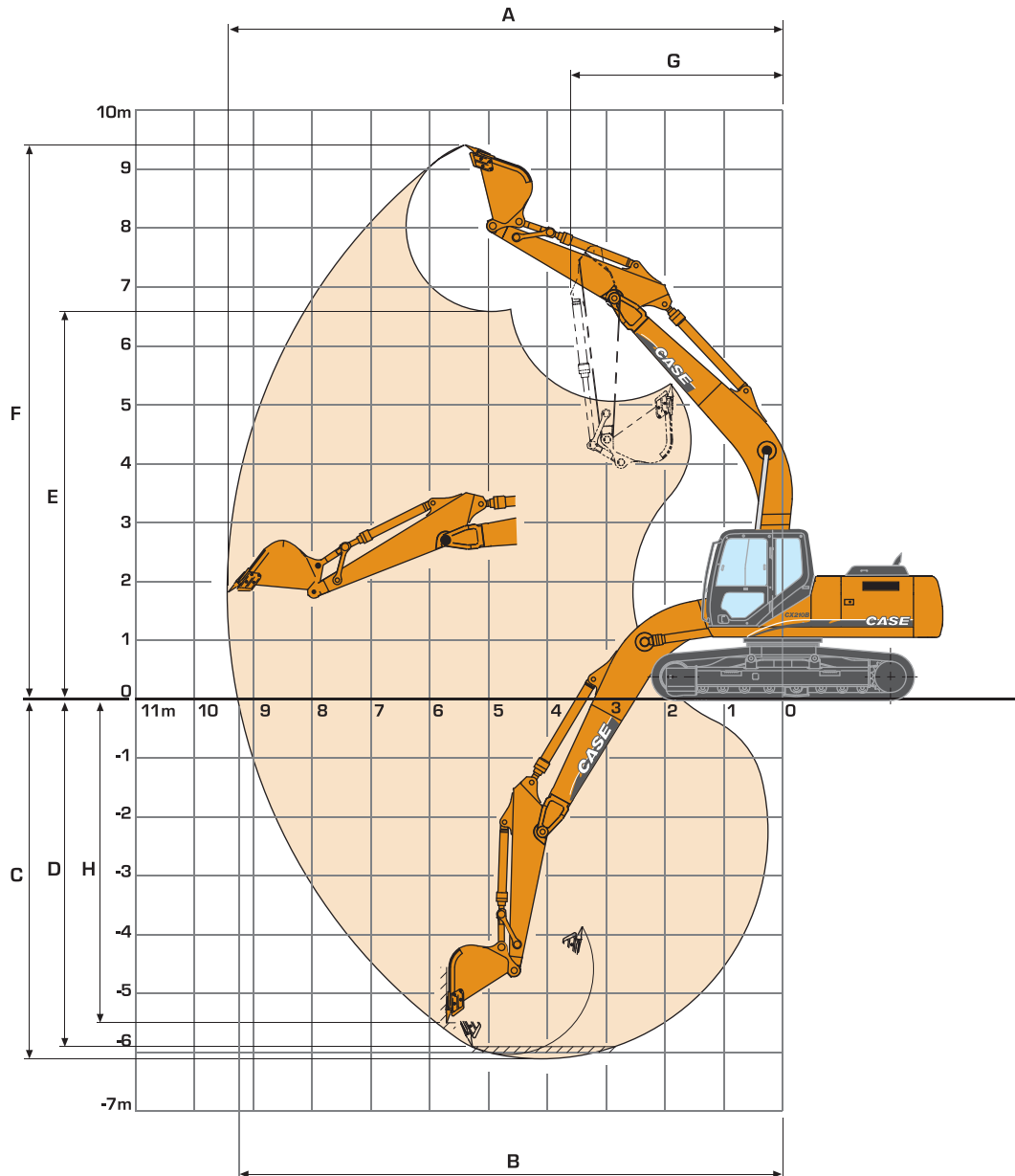

DIPPER LENGTH

		1.90 m	2.40 m	2.94 m	
A	Maximum digging reach	m	8.96	9.42	9.90
B	Maximum digging reach at ground level	m	8.77	9.24	9.73
C	Maximum digging depth	m	5.61	6.10	6.65
D	Digging depth - 2.44 m level bottom	m	5.37	5.90	6.47
E	Max dump height	m	6.36	6.62	6.84
F	Overall reach height	m	9.19	9.44	9.64
G	Minimum swing radius - attachment	m	3.58	3.60	3.60
H	Vertical straight wall dig depth	m	5.01	5.50	5.96
Digging force	- w/o Power Boost	daN	14 200	12 300	10 300
	- with Power Boost	daN	15 200	13 200	11 000
Breakout force	- w/o Power Boost	daN	14 200	14 200	14 200
	- with Power Boost	daN	15 200	15 200	15 200

CX210B

LIFTING CAPACITY

WITH 5.70 m STANDARD MONOBOOM

Values are expressed in kilos

Front 360°	REACH					m
	3.0 m	4.5 m	6.0 m	7.5 m	At max reach	

LC with 2.94 m dipper, 600 mm shoes and bucket of 0.90 m³ - 651 kg

6.0 m									2716*	2716*	7.46
4.5 m					4629*	4629*	4386*	3160	2731*	2709	8.13
3.0 m	10 818*	10 818*	6925*	6925*	5478*	4394	4785*	3020	2872*	2415	8.48
1.5 m	8056*	8056*	8726*	6344	6394*	4095	4667	2867	3157*	2290	8.55
0 m	8701*	8701*	9885*	5958	6447	3869	4533	2745	3654*	2308	8.36
-1.5 m	11 921*	11 532	10 234	5808	6316	3753	4468	2686	4149	2497	7.88
-3 m	14 471*	11 691	9844*	5829	6318	3755			4938	2973	7.05
-4.5 m	12 089*	12 054	8432*	6014					6339*	4191	5.72

LC with 2.40 m dipper, 600 mm shoes and bucket of 1.0 m³ - 698 kg

6.0 m					4541*	4541*			4570*	3809	6.79
4.5 m					5035*	4590	4717*	3085	4045*	2952	7.67
3.0 m			7555*	6775	5838*	4305	4775	2965	4232	2612	8.05
1.5 m			9195*	6192	6626	4025	4627	2830	4062	2474	8.13
0 m	7790*	7790*	10 091*	5880	6405	3830	4518	2730	4151	2508	7.92
-1.5 m	12 670*	11 572	10 188*	5795	6314	3750			4569	2751	7.41
-3 m	13 622*	11 800	9512*	5873	6369	3798			5609	3375	6.52
-4.5 m	10 776*	10 776*	7619*	6138					6625*	5154	5.05

LC with 1.90 m dipper, 600 mm shoes and bucket of 1.0 m³ - 698 kg

6.0 m					5079*	4733			5076*	4477	6.19
4.5 m			6515*	6515*	5510*	4563			5180*	3349	7.17
3.0 m			8243*	6664	6261*	4296	4789	2984	4720	2940	7.56
1.5 m			9705*	6144	6637	4044	4668	2874	4524	2784	7.65
0 m			10 313*	5917	6456	3884			4652	2840	7.43
-1.5 m	14 179*	11 801	10 143*	5896	6410	3843			5206	3163	6.89
-3 m	12 694*	12 065	9169*	6029					6668	4026	5.92
-4.5 m									7028*	7007	4.24

NLC with 2.94 m dipper, 500 mm shoes and bucket of 0.90 m³ - 651 kg

7.5 m									2804*	2804*	6.40
6.0 m									2671*	2671*	7.47
4.5 m					4599*	4037	4361*	2714	2695*	2313	8.13
3.0 m	10 722*	10 722*	6884*	5884	5453*	3749	4766*	2574	2844*	2047	8.48
1.5 m	8664*	8664*	8690*	5293	6373*	3459	4835	2423	3138*	1928	8.55
0 m	9097	9097*	9858*	4929	6668	3241	4698	2303	3651*	1935	8.35
-1.5 m	12 181*	9107	10 232*	4787	6536	3129	4633	2245	4316	2092	7.87
-3 m	14 492*	9247	9842*	4805	6537	3130			5138	2497	7.03
-4.5 m	12 127*	9569	8448*	4979					6421*	3539	5.69

NLC with 2.40 m dipper, 500 mm shoes and bucket of 1.0 m³ - 698 kg

7.5 m									4101*	4101*	5.82
6.0 m					4495*	4141			3916*	3114	6.99
4.5 m					5000*	3945	4683*	2646	3973*	2517	7.69
3.0 m	12 475*	10 376	7504*	5705	5809*	3666	4950	2523	4221*	2211	8.06
1.5 m			9152*	5153	6649*	3394	4798	2388	4213	2082	8.13
0 m	8331*	8331*	10 064*	4855	6627	3204	4685	2289	4308	2102	7.92
-1.5 m	12 985*	9137	10 180*	4773	6534	3126			4742	2304	7.41
-3 m	13 674*	9338	9523*	4844	6588	3171			5822	2832	6.51
-4.5 m	10 853*	9744	7666*	5092					6727*	4335	5.03

NLC with 1.90 m dipper, 500 mm shoes and bucket of 1.0 m³ - 698 kg

6.0 m					5028*	4099			4938*	3618	6.42
4.5 m			6461*	6228	5474*	3925			5069*	2867	7.18
3.0 m			8192*	5609	6233*	3663	4967	2547	4886	2503	7.58
1.5 m			9663*	5115	6865	3417	4841	2436	4689	2357	7.65
0 m	7688*	7688*	10 295*	4897	6681	3261			4825	2395	7.43
-1.5 m	14 472*	9347	10 146*	4874	6633	3220			5401	2666	6.88
-3 m	12 779*	9583	9196*	4997					6841*	3396	5.90
-4.5 m									7184*	5897	4.20

Machine in Auto mode Lift capacities are taken in accordance with SAE J1097/ISO 10567/DIN 15019-2 Lift capacities shown in kg do not exceed 75% of the tipping load or 87% of the hydraulic lift capacity Capacities that are marked with an asterisk (*) are hydraulic limited. If the machine is equipped with a quick coupler, subtract the weight of the quick coupler from the load shown in the table to calculate the real lift capacity

GENERAL DIMENSIONS

WITH 5.70 m ARTICULATED BOOM

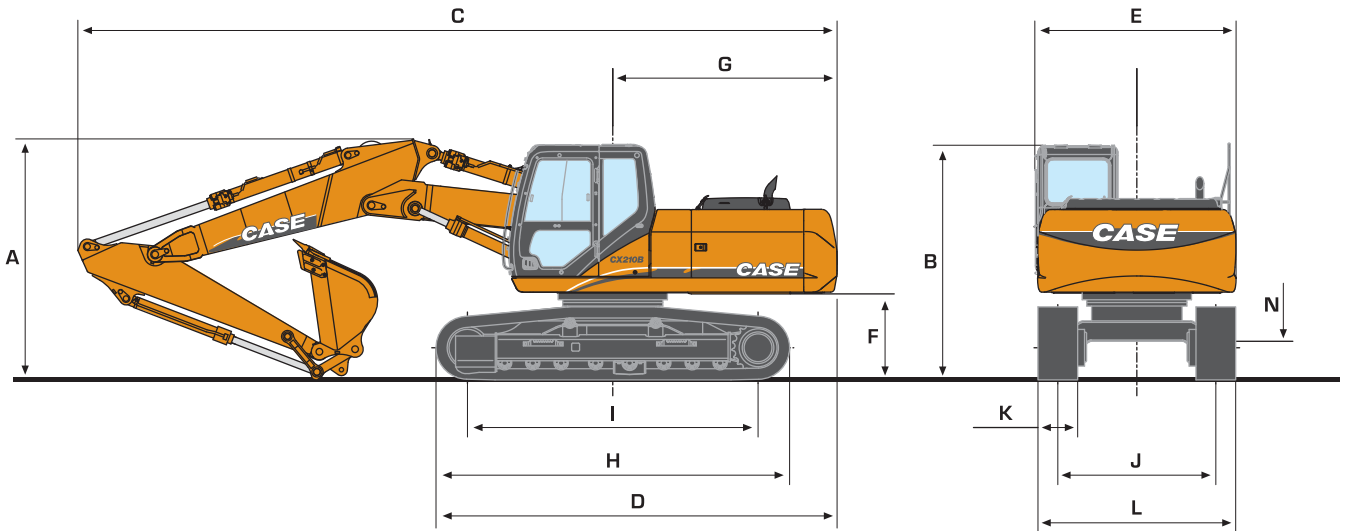

		CX210B NLC ART			
	Dipper length	m	1.90	2.40	2.94
A	Overall height (with attachment)	m	2.95	3.03	2.89
B	Height (cab/handrail)	m	2.97/2.99	2.97/2.99	2.97/2.99
C	Overall length (with attachment)	m	9.57	9.56	9.50
D	Overall length (without attachment)	m	5.05	5.05	5.05
E	Width of upperstructure	m	2.54	2.54	2.54
F	Upperstructure ground clearance	m	1.07	1.07	1.07
G	Swing radius (rear end)	m	2.83	2.83	2.83
H	Track overall length	m	4.47	4.47	4.47
I	Centre idler to centre sprocket	m	3.66	3.66	3.66
J	Track gauge	m	1.99	1.99	1.99
K	Track shoe width standard	mm	500	500	500
L	Track overall width - 500mm shoes	m	2.49	2.49	2.49
	- 600mm shoes	m	-	-	-
	- 700mm shoes	m	-	-	-
	- 800mm shoes	m	-	-	-
N	Ground clearance	m	0.46	0.46	0.46

WEIGHT AND GROUND PRESSURE

With 5.70 m articulated boom
2.40 m dipper
698 kg, 1 m³ bucket
operator and full fuel tank

	WEIGHT (kg)	GROUND PRESSURE (bar)
	NLC	NLC
shoes 500mm steel	22 200	0.55

CX210B

PERFORMANCE DATA

WITH 5.70 m ARTICULATED BOOM - 2.40 m DIPPER

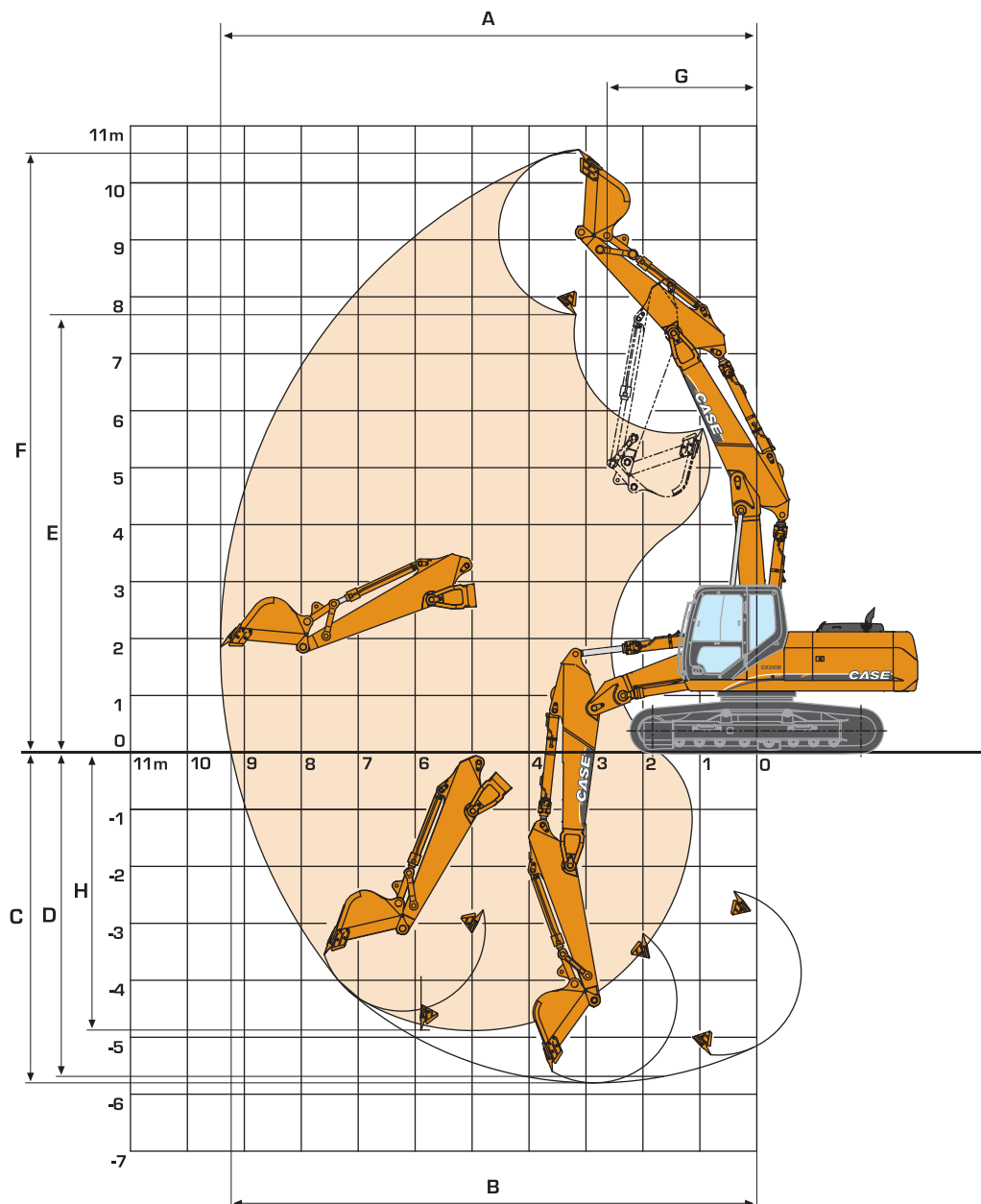

DIPPER LENGTH

		1.90 m	2.40 m	2.94 m	
A	Maximum digging reach	m	8.95	9.42	9.91
B	Maximum digging reach at ground level	m	8.76	9.23	9.73
C	Maximum digging depth	m	5.31	5.80	6.32
D	Digging depth - 2.44 m level bottom	m	5.37	5.90	6.47
E	Max dump height	m	7.32	7.69	8.04
F	Overall reach height	m	10.22	10.58	10.94
G	Minimum swing radius - attachment	m	2.46	2.63	2.37
H	Vertical straight wall dig depth	m	5.01	5.50	5.96
Digging force	- w/o Power Boost	daN	14 200	12 300	10 300
	- with Power Boost	daN	15 200	13 200	11 000
Breakout force	- w/o Power Boost	daN	14 200	14 200	14 200
	- with Power Boost	daN	15 200	15 200	15 200

ARTICULATED

LIFTING CAPACITY

WITH 5.70 m ARTICULATED BOOM

Values are expressed in kilos

Front 360°	REACH											
	1.5 m	3.0 m	4.5 m	6.0 m	7.5 m	At max reach						m

NLC with 2.94 m dipper, 500 mm shoes and bucket of 0.90 m³ - 651 kg

7.5 m						3740*	3740*				2750*	2750*	6.40
6.0 m						4680*	4340				2610*	2610*	7.50
4.5 m				6320*	6320*	4940*	4300*	3980*	2710		2620*	2200	8.20
3.0 m	18 350*	13 280*	11 540	7820*	6360	5500*	4120	4320*	2620		2760*	1930	8.50
1.5 m	14 340*	14 650*	11 190	9700*	6070	6350*	3920	4690*	2460		3030*	1800	8.60
0 m	12 710*	15 520*	10 490	10 030*	5640	6870*	3560	4740	2270		3520*	1800	8.40
-1.5 m	14 780*	15 830*	9760	10 070*	5210	6770	3230	4600	2140		4150*	1960	7.90
-3 m	15 940*	16 040*	9540	10 150*	4920	6560	3060				4480*	2360	7.10
-4.5 m	16 560*	12 820*	9480	7380*	4860						4240*	3520	5.60

NLC with 2.40 m dipper, 500 mm shoes and bucket of 1.0 m³ - 698 kg

7.5 m				5740*	5740*						4050*	4050*	5.80
6.0 m				6040*	6040*	4950*	4240				3840*	3010	7.00
4.5 m			9940*	9940*	6810*	6550	5220*	4220	4110*	2570	3720*	2400	7.70
3.0 m	16 000*	14 350*	11 380	8580*	6320	5810*	4060*	4550*	2490		3640*	2080	8.10
1.5 m	9970*	14 740*	11 180*	9910*	6000	6700*	3760	4840	2350		3750*	1950	8.10
0 m	13 250*	15 700*	10 170	10 020*	5490	6870	3420	4670	2200		4070*	1960	7.90
-1.5 m	16 760*	15 930*	9640	10 130*	5150	6680	3150				4660	2160	7.40
-3 m	18 650*	15 800*	9580	9750*	4870	6030*	3050				4530*	2690	6.50
-4.5 m													

NLC with 1.90 m dipper, 500 mm shoes and bucket of 1.0 m³ - 698 kg

7.5 m				6350*	6350*						5080*	5080*	5.10
6.0 m				6540*	6540*	5310*	4100				4650*	3510	6.40
4.5 m			11 940*	11 940*	7440*	6560	5600*	4090			4270*	2740	7.20
3.0 m	15 420*	14 160*	11 390	9400*	6310	6230*	3920	4450*	2430		4180*	2370	7.60
1.5 m		15 220*	11 020	10 120*	5970	7000	3650	4790	2320		4320*	2210	7.70
0 m	14 830*	15 900*	10 020	10 140*	5460	6920	3360				4730*	2250	7.40
-1.5 m	18 990*	16 180*	9680	10 340*	5120	6670	3160				5920*	2520	6.90
-3 m	20 450*	14 910*	9620	8960*	4930						4670*	3250	5.90
-4.5 m													

Machine in Auto mode

Lift capacities are taken in accordance with SAE J1097 / ISO 10567 / DIN 15019-2

Lift capacities shown in kg do not exceed 75% of the tipping load or 87% of the hydraulic lift capacity

Capacities that are marked with an asterisk (*) are hydraulic limited

If the machine is equipped with a quick coupler, subtract the weight of the quick coupler from the load shown in the table to calculate the real lift capacity





GENERAL DIMENSIONS

WITH 8.70 m LONG REACH BOOM

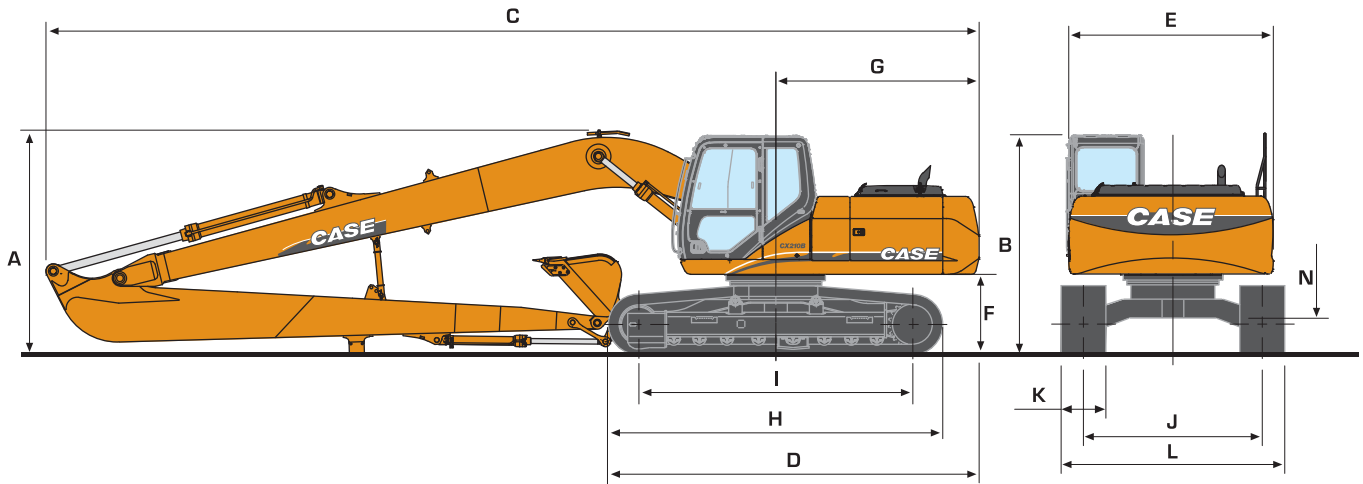

CX210B LR

DIPPER LENGTH

6.40 m

Dimension	Unit	Value
A Overall height (with attachment)	m	3.00
B Height (cab/handrail)	m	2.94/2.96
C Overall length (with attachment)	m	12.47
D Overall length (without attachment)	m	4.96
E Width of upperstructure	m	2.77
F Upperstructure ground clearance	m	1.04
G Swing radius (rear end)	m	2.72
H Track overall length	m	4.47
I Centre idler to centre sprocket	m	3.66
J Track gauge	m	2.39
K Track shoe width standard	m	800
L Track overall width - 500mm shoes	mm	-
- 600mm shoes	m	2.99
- 700mm shoes	m	3.09
- 800mm shoes	m	3.19
N Ground clearance	m	0.46

WEIGHT AND GROUND PRESSURE

With 8.70 m long reach
boom 6.40 m dipper
330 kg, 0.37m³ bucket
operator and full fuel tank

	WEIGHT (kg)	GROUND PRESSURE (bar)
shoes 600 mm steel	22 300	0.46
shoes 800 mm steel	23 100	0.36

BUCKETS

GENERAL PURPOSE

SAE capacity	l	370	470
Width	mm	610	760

DITCH

SAE capacity	l	760
Width	mm	1520

LONG REACH

PERFORMANCE DATA

WITH 8.70 m LONG REACH BOOM - 6.40 m DIPPER

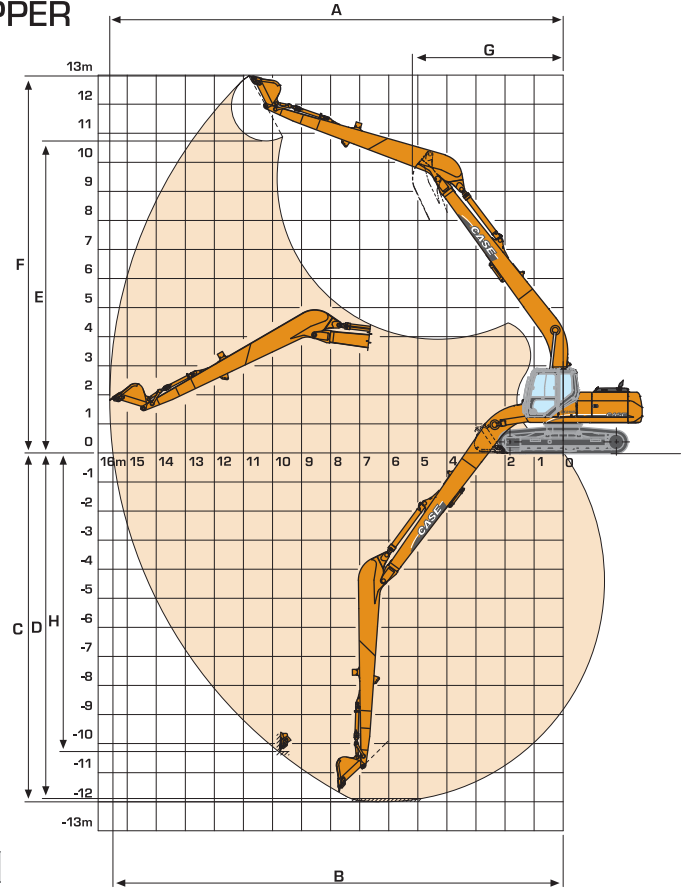

DIPPER LENGTH

6.40 m

A	Maximum digging reach	m	15.60
B	Maximum digging reach at ground level	m	15.49
C	Maximum digging depth	m	12.01
D	Digging depth - 2.92 m level bottom	m	11.82
E	Max dump height	m	10.73
F	Overall reach height	m	12.97
G	Minimum swing radius - attachment	m	5.19
H	Vertical straight wall dig depth	m	10.29
	Digging force	daN	4600
	Breakout force	daN	6500

LIFTING CAPACITY

WITH 8.70 m LONG REACH BOOM

Front 360°	REACH								
	3.0 m	4.5 m	6.0 m	7.5 m	9.0 m	10.5 m	12.0 m	13.5 m	At max reach
	m								

LR with 6.40 m dipper, 800 mm shoes and bucket of 0.37 m³ - 338 kg

10.5 m																			1039*	1039*	11.45	
9.0 m																				994*	994*	12.46
7.5 m																				978*	978*	13.21
6.0 m																				983*	983*	13.76
4.5 m																				1009*	1009*	14.14
3.0 m																				1056*	974	14.34
1.5 m	3064*	3064*	6482*	6482*	4533*	4400	3546*	3160	2968*	2362	2596*	1804	2346*	1391	1918	1073	1128*	917			14.39	
0 m	2508*	2508*	5950*	5763	5336*	3894	4073*	2840	3326*	2149	2834	1659	2274	1293	1852	1009	1229*	889			14.27	
-1.5 m	2880*	2880*	5167*	5167*	5914*	3559	4487	2599	3424	1979	2707	1540	2188	1211	1799	959	1371*	889			14.0	
-3.0 m	3482*	3482*	5366*	5154	6040	3372	4316	2444	3297	1861	2616	1454	2128	1154	1690*	930	1573*	923			13.55	
-4.5 m	4199*	4199*	5974*	5125	5955	3298	4231	2366	3227	1796	2566	1407	2101	1128			1871*	999			12.91	
-6.0 m	5016*	5016*	6860*	5198	5968	3309	4219	2356	3213	1783	2562	1404	2118	1144			2104	1136			12.06	
-7.5 m	5943*	5943*	7968*	5358	5993*	3394	4278	2409	3260	1827	2616	1454					2477	1375			10.93	
-9.0 m	6998*	6998*	7063*	5612	5387*	3558	4251*	2533	3379*	1942							3149*	1821			9.43	
-10.5 m			5607*	5607*	4303*	3830											3398*	2855			7.34	

Machine in Auto mode Lift capacities are taken in accordance with SAE J1097 / ISO 10567 / DIN 15019-2 Lift capacities shown in kg do not exceed 75% of the tipping load or 87% of the hydraulic lift capacity Capacities that are marked with an asterisk (*) are hydraulic limited. If the machine is equipped with a quick coupler, subtract the weight of the quick coupler from the load shown in the table to calculate the real lift capacity

CX210B

STANDARD EQUIPMENT & OPTIONS

STANDARD EQUIPMENT

Engine control

- Common rail engine Tier III European Standards
- Electronic control of the injection system
- Automatic engine pre-heating
- Automatic/manual engine return to idle
- Exhaust Gas Recirculator
- Emergency stop
- Electrical refuel pump with automatic stop
- Fuel filter with water separator

Hydraulic control

- Auto/Heavy/Super Power working modes
- Pump torque variable control
- Automatic Power boost control
- Swing brake control
- High performance "Super Fine" synthetic fiber hydraulic filter (high contamination catch)
- Hydraulic safety valves on boom and dipper
- 2 travel speeds with auto down shifting

Operator environment

- High visibility cab with safety glass
- Adjustable and retractable armrest console with position memory
- Safety lever
- Self adjusting Air conditioning and heating system
- Cup holder
- High visibility side monitor display with automatic brightness
- Messages (function, temperature, safety, ...) on the display
- Integrated diagnostic system
- Working modes (Auto/Heavy/Super Power) combined with engine throttle
- Anti-theft device
- Hourmeter
- Selectable auxiliary hydraulic flow pre-settings
- RH front console with clock and cell phone holder
- High capacity shock absorbers on cab with 4 points fluid mountings
- Rain deflector
- Windscreen with lockable opening
- Windscreen washer and wiper
- Removable lower front windscreen with storage location in cab
- Glass cab roof window and sliding sun shade
- ISO control pattern low effort & short joysticks
- Adjustable sun visor

- Washable cab floor mat
- Rear view mirror and safety mirrors
- Storage compartments
- Integrated cool box
- 12V and 24V DC accessory sockets
- Hammer/Shear change selected from the cab
- Fore & aft adjustment of the whole seat & console

Electrical system

- Water proof connectors
- Double horn
- 2 working light on the cab
- Working light on the fuel tank
- Working light on the boom

Equipment

- EMS (Extended Maintenance System) pins and bushings as Standard (1000 hours lubrication interval for all, except buckets pins at 250 hours)
- Low friction resin side shims on boom and dipper
- Sealed and lubricated tracks
- Track guides (1 guide & front)
- Large tool box
- Pre-disposal for the optional cab protection

Operator seat

- Fully adjustable low frequency air suspension seat including double acting hydraulic damper
- Adjustable head rest
- Adjustable seat back angle with Fully flat seat reclining
- Adjustable arm rest
- Adjustable lombar position
- Height/fore & aft adjustment
- Safety belt

OPTIONS

- Bucket/clamshell hydraulic circuit
- Hammer hydraulic circuit
- Hammer/shear hydraulic circuit
- Additional track guides (3 guides & front)
- Track width (500mm - 600mm - 700mm - 800mm depending on the version)
- Windscreen protection
- Cab protection
- GPS (Global Positioning System) by satellite
- Centralized greasing system automatically actuated by an electrical grease pump

Standard and optional equipment shown can vary by country.



CNH INTERNATIONAL SA
Riva Paradiso, 14
6902 Paradiso
SWITZERLAND

NOTE: Standard and optional fittings can vary according to the demands and specific regulations of each country. The illustrations may include optional rather than standard fittings - consult your Case dealer. Furthermore, CNH reserves the right to modify machine specifications without incurring any obligation relating to such changes.



Conforms to directive 98/37/CE

www.casece.com

CASE
CONSTRUCTION